

StrongHandTools

RHINO CART
MOBILE FIXTURING STATION

2020 METRIC CATALOG



Table + Fixture Kit

ALL-IN-ONE

Mobility & Storage

CHARGE RIGHT THROUGH YOUR
MOST CHALLENGING PROJECTS!

www.Rhino-Cart.com

562.949.5625

The Rhino Cart® Mobile Fixturing Station is a turnkey system for fixturing and clamping in welding and fabrication. Clamp and fixture at any point on the reversible, flat ground, nitrided (heat treated) 1,200 x 750 mm tabletop for accuracy in all of your setups.

Be ready to handle any job with the Rhino Cart® package, including: the Rhino Cart® Welding Table + Fixture Kit.

(Kit content may differ from image.)

Nitrided **REVERSIBLE** Tabletop resists weld spatter and rust.

Quickly clamp and fixture at any point on the surface. Accurately setup stock for each new project.

2x LIFE

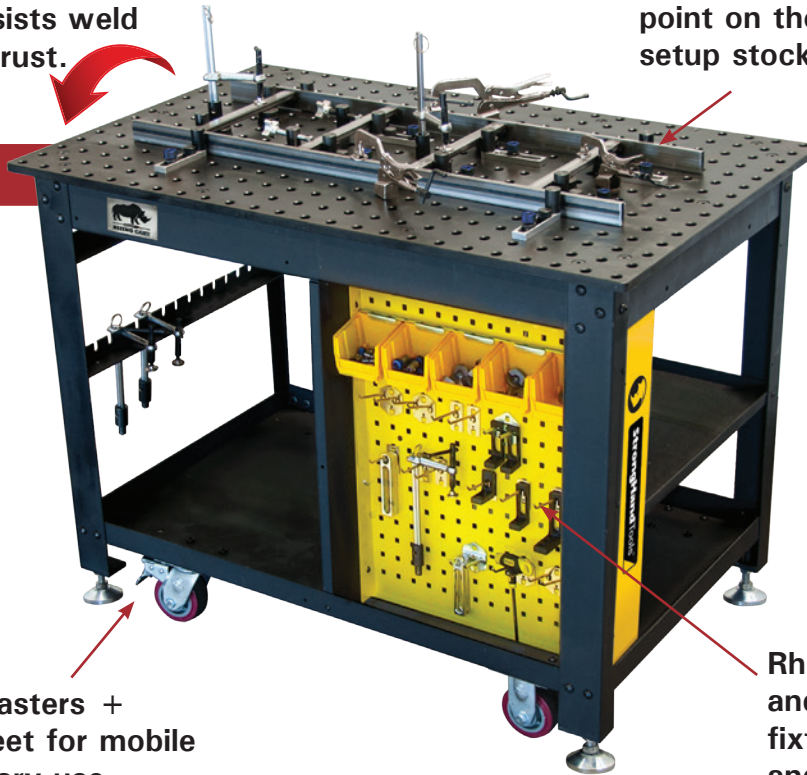
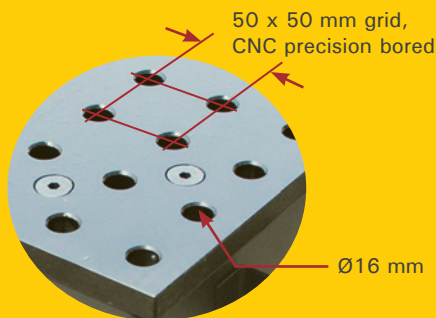

Table + Fixture Kit
ALL-IN-ONE
Mobility & Storage

Locking casters + leveling feet for mobile or stationary use.

Rhino shelves, racks, and pegboard keep your fixturing tools organized and within easy reach!



Accurately position parts in CNC precision bored 16 mm dia. holes in 50 x 50 mm spacing pattern.

Rhino Cart Part No.:	TDQ612075
Tabletop Size:	1,200 x 750 mm
Tabletop Thickness:	16 mm
Tabletop Flatness:	0.5 mm / 1,000 mm
Hole Diameter:	16 mm
Grid Pattern:	50 x 50 mm
Table Height:	910 mm
Static Loading Capacity:	680 kg
Tabletop Life:	Nitrided and black oxide table plate is REVERSIBLE . Weld spatter, rust and scratch resistant.



GUIDELINES FOR MODULAR FIXTURING

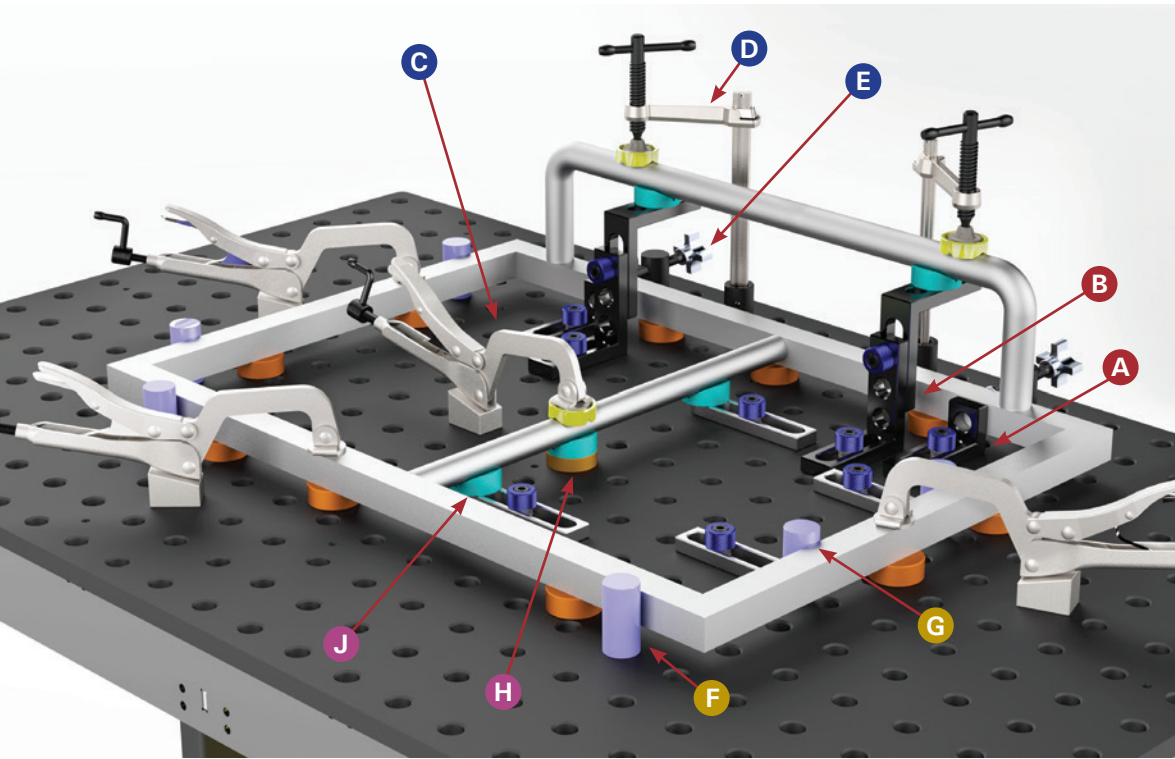

*** Ball Lock Bolts** are **ESSENTIAL** to Modular Fixturing!

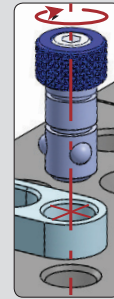

Finger tighten to pre-load, before tightening with hex key.

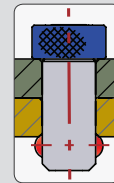

Three locking steel balls move outward to lock the bolt in position.

Stop / Locate / Elevate

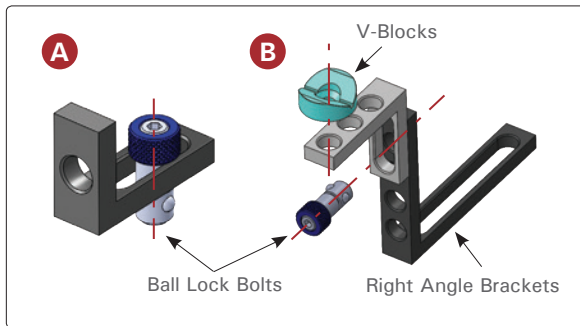

Stop and locate parts.

Stack Right Angle Brackets to elevate and hold round parts.

Clamp

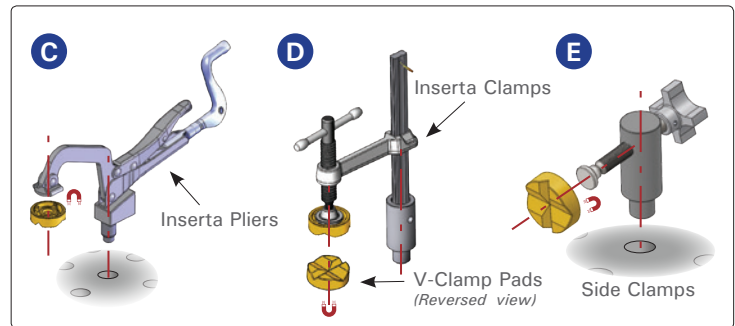

Quick hold-down clamping of flat, square, angled or round parts.

Hold, stop, or locate parts using horizontal clamping force.

Locate / Stop

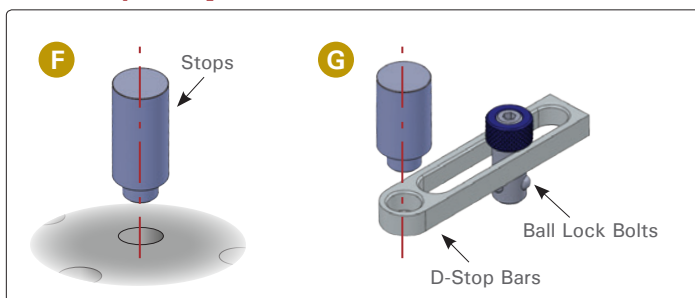

Stop, locate, and position parts.

Support Round Stock

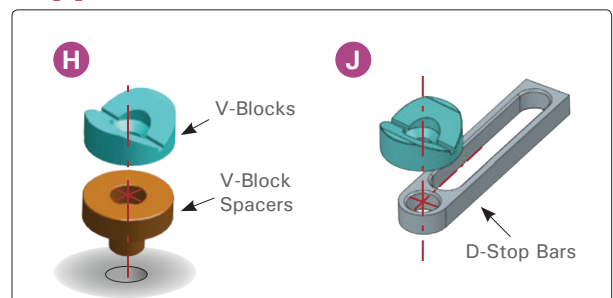

Elevate and hold round parts.

The Rhino Cart® Package Part No. TDQ612075-K1 includes the mobile welding table + 66 pc. fixturing kit TDK6100.

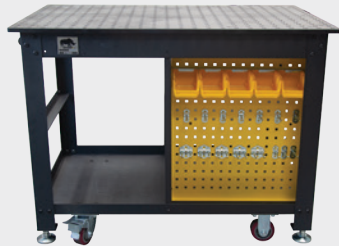

TDQ612075 x1

Welding Table, 1,200 x 750 mm, 910 mm height, 16 mm thickness, 16 mm dia. hole, 50 x 50 mm grid pattern, 680 kg static loading capacity, long life **REVERSIBLE** tabletop.

185 kg



UDN6150 x2

Inserta Clamp, T-Handle
150 mm opening,
83 mm reach,
16 x 8 mm (D Rail)

0.6 kg



PT07K x2

Inserta Pliers,
60 mm opening,
50 mm reach

0.3 kg



PT09K x2

Inserta Pliers,
100 mm opening,
75 mm reach

0.4 kg

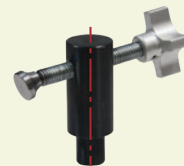

TCX6210 x2

Side Clamp,
38 mm stroke

0.3 kg



T64217 x2

Magnetic V-Clamp Pad
PATENTED

0.02 kg

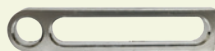

T60630 x8

Stop / Extend
Aluminum D-Stop Bar,
121.2 x 25 x 11.5 mm

0.04 kg



T60304 x2

Stop / Support
Right Angle Bracket,
41 x 91 x 30 mm

0.2 kg



T60305 x2

Right Angle Bracket,
91 x 91 x 30 mm

0.3 kg

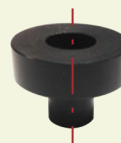

T64211 x4

Locate / Support
V-Block Spacer,
Ø38 x 11.5 mm

0.1 kg



T64216 x8

V-Block,
Ø40 x 22.6 mm

0.02 kg



T50737 x12

Spacer
Magnetic Rest Button,
Ø40 x 11.5 mm H

0.1 kg



T65055 x10

Locate / Lock
Ball Lock Bolt, Adjustable
range: 22 ~ 27 mm,
connecting tables to
accessories, and
accs. to accs.

0.07 kg



T64201 x2

Locating Pin goes into
16 mm holes,
33.5 mm H,
no locking.

0.07 kg



T64203 x4

Locate
Stop,
Ø25 x 38 mm H

0.18 kg



T64205 x4

Stop,
Ø25 x 50 mm H

0.22 kg



The Rhino Cart® Package Part No. TDQ612075-K2 includes the mobile welding table + 122 pc. fixturing kit TDK6200.

UDN6150 x4	PT09K x2	T51655 x2	UDV45M x4	T64217 x6	T64211 x4	T64216 x20
← Clamp →			← Locate / Support →			
Inserta Clamp, T-Handle 150 mm opening, 83 mm reach, 16 x 8 mm (D Rail)	Inserta Pliers, 100 mm opening, 75 mm reach	T-Post Clamp, 114 x 83 mm, T-Handle	MagSpring Clamp, 75 mm capacity, 83 mm throat depth	Magnetic V-Clamp Pad <i>*PATENTED*</i>	V-Block Spacer, Ø38 x 11.5 mm	V-Block, Ø40 x 22.6 mm
0.6 kg	0.4 kg	0.6 kg	0.5 kg	0.02 kg	0.1 kg	0.02 kg
T60210 x2	T60305 x2	T60310 x2	T60320 x5	T60330 x4	T60505 x2	T60630 x4
← Stop / Support →					← Stop / Extend →	
Econo Stop, 50 x 138 x 200 mm	Right Angle Bracket, 91 x 91 x 30 mm	Right Angle Bracket, 90 x 150 x 30 mm	Right Angle Bracket, 193 x 150 x 30 mm	Right Angle Bracket, 300 x 150 x 50 mm	Straight Edge Stop, 150 x 30 x 12 mm	Aluminum D-Stop Bar, 121.2 x 25 x 11.5 mm
1.7 kg	0.3 kg	0.4 kg	0.6 kg	2.0 kg	0.2 kg	0.04 kg
T60510 x4	T60517 x3	T65055 x42	T64201 x2	T65020 x4	T932607 x2	T65804 x2
← Stop / Support →		← Locate / Lock →				Spacer
Straight Edge Stop, 200 x 30 x 12 mm	Straight Edge Stop, 250 x 30 x 12 mm	Ball Lock Bolt, adjustable range: 22 ~ 27 mm, connecting tables to accessories, and accs. to accs.	Locating Pin goes into 16 mm holes, 33.5 mm H, no locking	Ball Lock Bolt, flush, 24 mm capacity, connecting 2 accessories	Socket Shoulder Screws Set, flush, 20 mm	Receiver Bushing, 4 mm thick, use with 24 mm Ball Lock Bolts for 28 mm combined thickness
0.3 kg	0.4 kg	0.07 kg	0.07 kg	0.05 kg	0.04 kg	0.01 kg

RHINO CART®

MOBILE FIXTURING STATION

Part No.	Description	Net Weight (kg)
TDQ612075-K1	Welding Table (TDQ612075) + 66 pc. Fixturing Kit (TDK6100)	195
TDQ612075-K2	Welding Table (TDQ612075) + 122 pc. Fixturing Kit (TDK6200)	213
TDQ612075	Welding Table Only	185
TDK6100	66 pc. Fixturing Kit Only	10
TDK6200	122 pc. Fixturing Kit Only	28

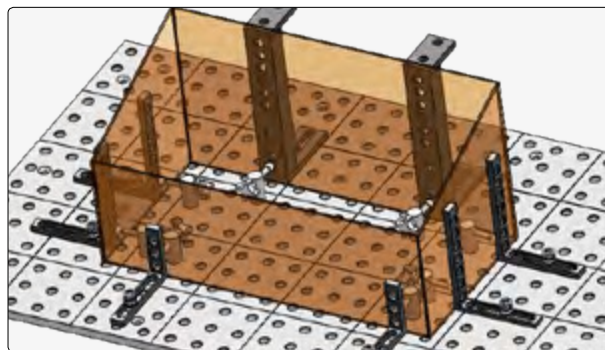
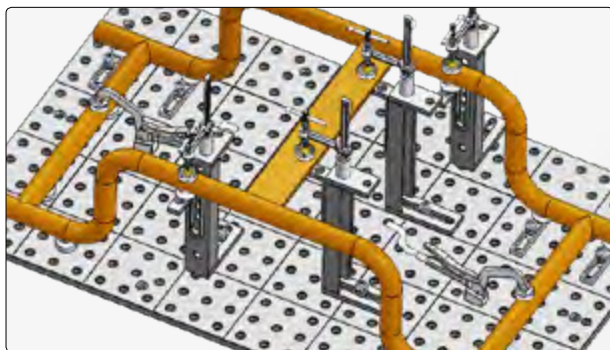
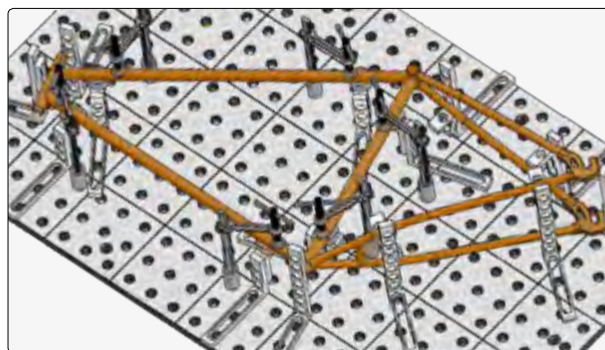
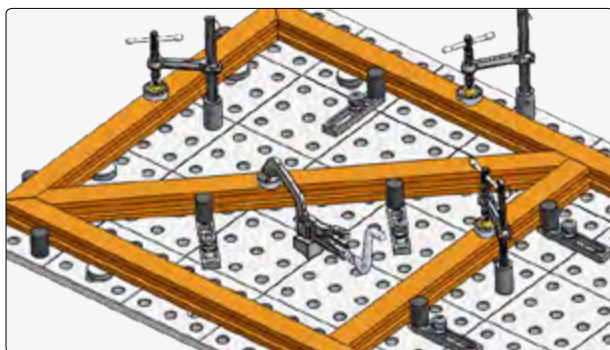
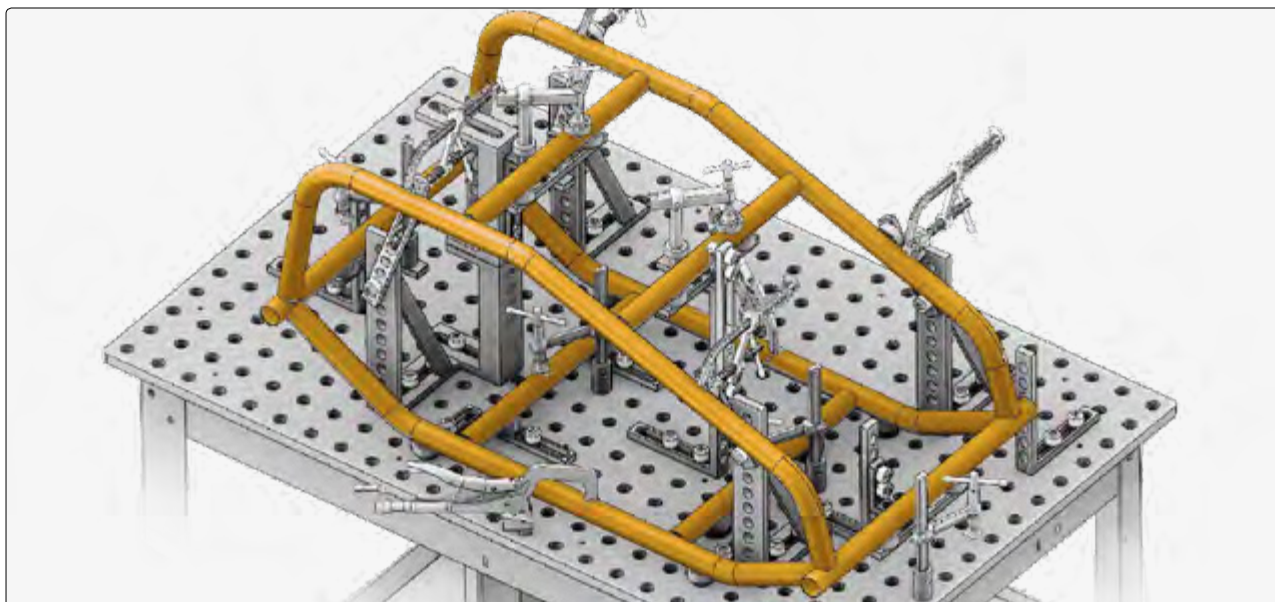



OPTIONAL EXTRA KITS

Increase your clamping and fixturing capabilities, and be ready to handle new projects with these Rhino Cart® Fixturing Kits. See the full selection of BuildPro® products at: www.StrongHandTools.com.

Part No: T65056 **Total: 10 pcs** **Gross Weight: 1 kg**





Connecting tables to accessories, and accs. to accs.

T65055 x10

Ball Lock Bolt, adjustable range: 22~27 mm, connecting tables to accessories, and accessories to accessories | 0.07 kg

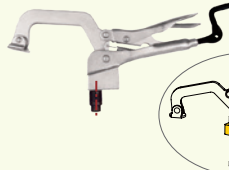
Part No: TMK600-10 **Total: 6 pcs** **Gross Weight: 4 kg**

T61670 x2 **PT11K x2** **T66010 x2**

Pivoting T-Post Clamp, Max. 124 mm capacity | 0.9 kg

Inserta Pliers, 100 mm opening, 85 mm reach | 0.7 kg

Mounting Adaptor, extended reach of Inserta Pliers | 0.18 kg

Part No: TMK600-20 **Total: 4 pcs** **Gross Weight: 22 kg**







T60231 x1 **T60230 x1** **T60130 x2**

Malleable Cast Iron Clamping Square, left angle, 50 x 140 x 300 mm | 2.9 kg

Malleable Cast Iron Clamping Square, right angle, 50 x 140 x 300 mm | 2.9 kg

Riser Block, 100 x 100 x 300 mm | 7.8 kg

Part No: TMK600-30 **Total: 6 pcs** **Gross Weight: 6 kg**





T60310 x2 **T60320 x2** **T60330 x2**

Right Angle Bracket, 90 x 150 x 30 mm | 0.4 kg

Right Angle Bracket, 193 x 150 x 30 mm | 0.6 kg

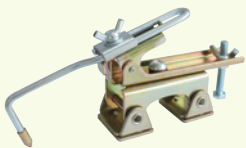
Right Angle Bracket, 300 x 150 x 50 mm | 2.0 kg

Part No: TMK500-05 **Total: 7 pcs** **Gross Weight: 5 kg**

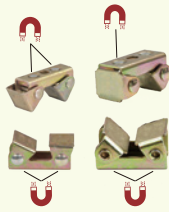
AGH230 x1 **MSA46-HD x2** **MLD600 x2** **XPV830 x1** **MVDF42 x1**

Magnetic Grasshopper, 15 kg magnetic pull force | 0.6 kg

Adjust-O™ Magnet, 40 kg magnetic pull force | 0.7 kg

Inside/Outside Magnet, fixed angle, 18 kg magnetic pull force | 0.8 kg

Adjustable V-Pad Magnet, 26 kg magnetic pull force | 0.6 kg

MagRest V-Pad Kit | 0.3 kg



Add a **Plasma Cutting Tray** to your **Rhino Cart® Mobile Fixturing Station**

PLASMA CUTTING TRAY

The Plasma Cutting Tray supports 45 kg, on a 450 x 710 mm cutting surface with 14 reversible / replaceable steel slats. Generous 45 mm width between cutting slats provides ample space for hold-down clamping. Slats remain secured in place when tray is folded.

Cut, clamp and fixture on one convenient mobile work station at the ideal, uniform working height.



The fold-out Plasma Cutting Tray easily folds down flat against the Rhino Cart® when not in use.

Part No.	Cutting Area	Holding Capacity	Weight
TPL3021	450 x 710 mm	45 kg	14.4 kg
TPLK3021	14 Reversible / Replaceable Slats		4.5 kg

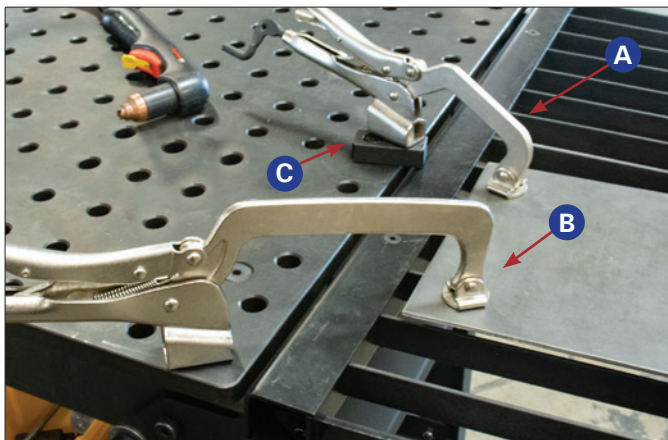

[Insert the Inserta Pliers into the 16 mm holes on the Rhino Cart® Tabletop.]
* See product details at: www.StrongHandTools.com.

We recommend using BuildPro® Inserta Pliers, to clamp down workpieces on the tray.

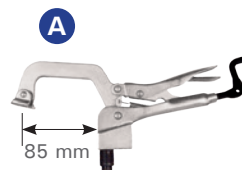

Inserta Pliers
Part No. PT11K

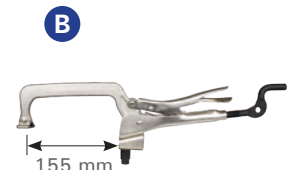

Inserta Pliers
Part No. PT14K



Mounting Adaptor
Part No. T66010

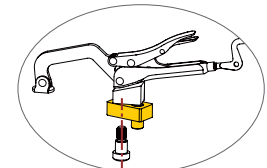



MODULAR BUILDPRO® TUBE & PIPE NOTCHER

Notch tubes and pipes at the accurate angle *and* length.

The 1st notch in a tube or pipe is easily completed with a drill press. The BuildPro® Tube & Pipe Notcher makes alignment, off-set and length control of the 2nd notch easy to complete accurately. Notch 25 – 63.5 mm OD pipes or square tubes at any angle, or off-set.

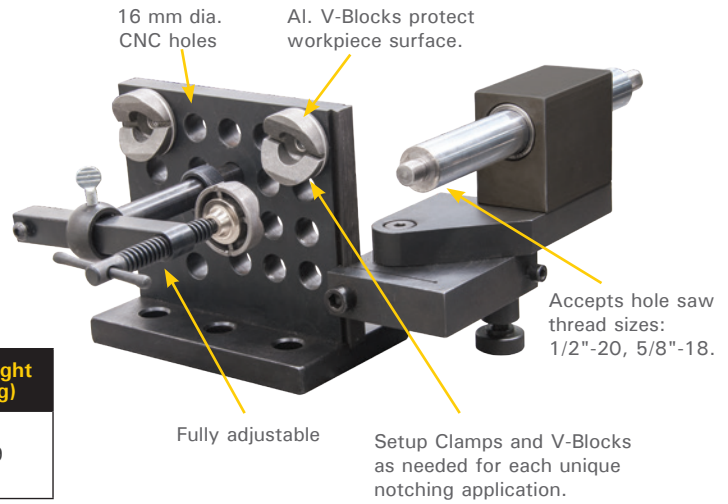

Part No.	Kit Includes	Weight (kg)
ATN100M	1 pc. BuildPro® Tube & Pipe Notcher 2 pcs. Aluminum V-Blocks for tube locating 1 pc. Clamp with Magnetic V-Pad	9

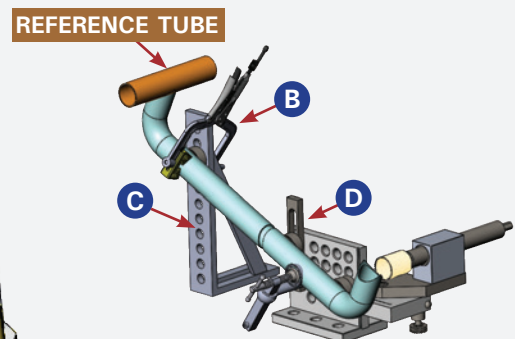
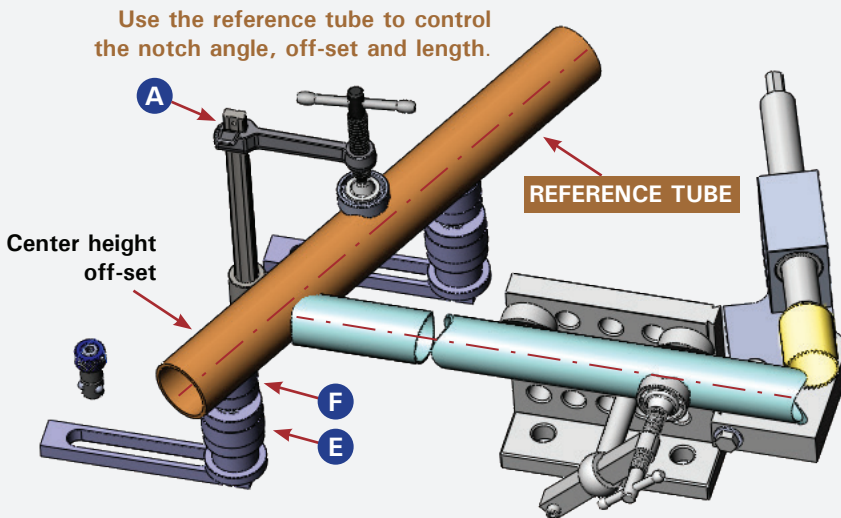

Compound Angles
Setup bent stock with the proper support and alignment for compound angle notching.

We recommend these optional BuildPro® Clamping Elements:

 <p>A</p>	 <p>B</p>	 <p>C</p>	 <p>D</p>	 <p>E</p>	 <p>F</p>
<p>Inserta Clamp Part No. UEN6200</p>	<p>Round Stock Pliers Part No. PG637V</p>	<p>Right Angle Bracket Part No. T60330</p>	<p>Straight Edge Stop Part No. T60505</p>	<p>Adjustable Rest Part No. T64213</p>	<p>Low Profile Adjustable Rest Part No. T64212</p>

FORGED VISE

This forged steel 100 mm Bench Vise features a 360° swivel base, large machined anvil surface, powder coated finish. Made of 90,000 PSI tensile strength forged steel.

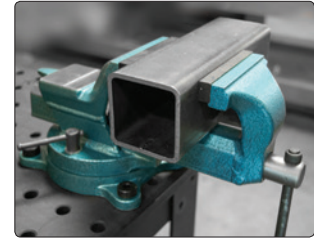
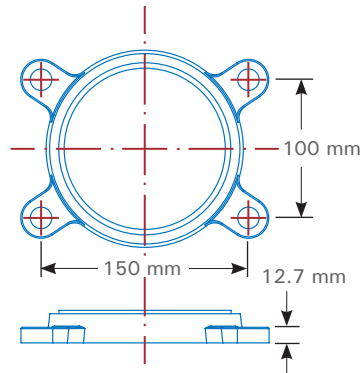
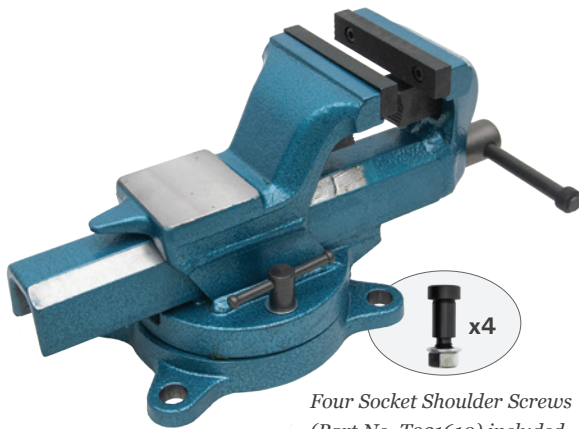

Part No.	Jaw Width	Jaw Opening	Pipe Capacity	Throat Depth	Clamping Force	Handle Dia.	Handle Length	Max Torque	Weight
TXV6-4-K	100 mm	127 mm	12 ~ 50 mm	73 mm	2,200 kg	11 mm	180 mm	160 N·m	10 kg

SIDE BRACKET

Locate or clamp your weldment at or beyond the table edge, by mounting the Side Bracket at the edge of your Rhino Cart® and BuildPro® Welding Table.

Use the Side Bracket to vertically mount clamping elements, such as the Straight Edge Stops or Right Angle Brackets for oversized weldments.



(Two Connecting Bolts, Part No. T932607 Included)

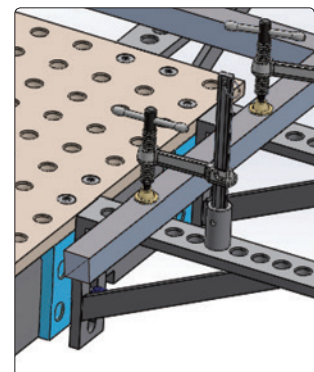
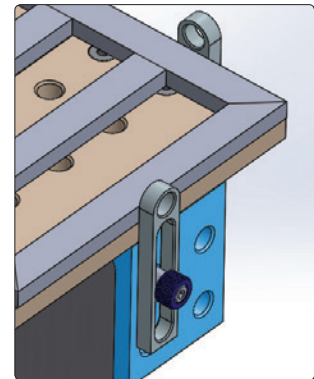
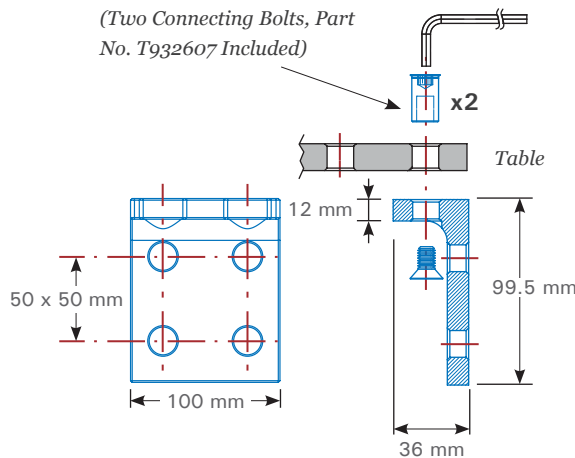

Part No.	Weight
T61825	1.1 kg



The Rhino Cart[®] Tabletop is COMPATIBLE WITH all BuildPro[®] Clamps, Components, and Modular Fixturing Kits.

[The exceptions are: Sliding Channel Clamps and Sliding Channel Bases]

BUILDPRO[®]
Welding Tables



Increase your fixturing options and capabilities by using the BUILDPRO[®] FIXTURING ELEMENTS.

Product suggestions:



ROUND STOCK PLIERS



MULTI-DIRECTIONAL PIVOTING T-POST CLAMP



ECONO STOP & CLAMPING SQUARES



RIGHT ANGLE BRACKET

See the full selection of BuildPro[®] products at: www.StrongHandTools.com.



POSITION, CLAMP, and FIXTURE accurately for higher quality welding and fabrication.

Visit StrongHandTools.com for details on the full line of Strong Hand Tools® products:

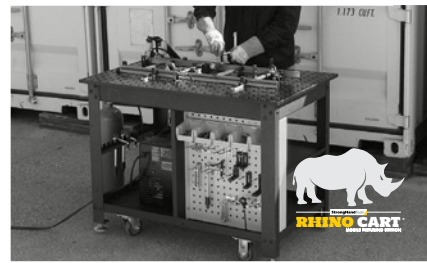
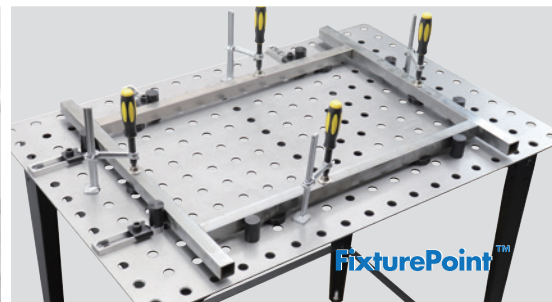
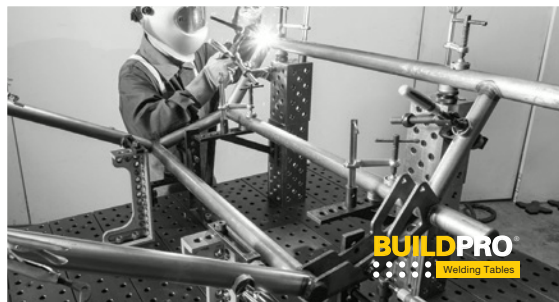
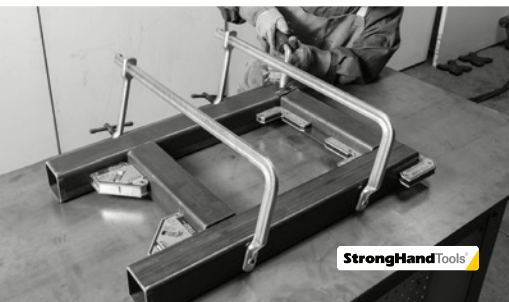

Contact Us:

562.949.8625
www.stronghandtools.com
sales@stronghandtools.com
Santa Fe Springs, CA 90670 U.S.A.

© 2018-2020 Strong Hand Tools. All Rights Reserved.

