



FEpowerTools®

PRODUCT CATALOG

POWER TOOLS AND ACCESSORIES



MAGNETIC DRILLING MACHINES | PIPE CUTTING MACHINES | BEVELING MACHINES | LUBRICANTS AND MUCH MORE...



Fe Powertools lighten your workload even in heavy-duty construction applications.

We are your specialist for all kinds of machine tools, such as magnetic drilling machines, cutting machines, beveling machines, and all other tools and accessories used in the metal and steel industry. Fe Powertools offers a wide range of constantly innovated magnetic drilling machines and hole cutters, which are produced in a high-tech factory in Germany. Furthermore, we specialize in various other products such as Europe-made beveling machines and pipe cutting machines from Finland. Fe Powertools stands for top quality and top service. All the Fe Powertools machines conform to the basic requirements of the relevant EC directives.

Fe Powertools is exclusive importer for:

- *BDS Maschinen Magnetic drilling machines and hole cutters*
- *Exacttools Pipe cutting machines*
- *NKO beveling machines*
- *REMO punch and dies*
- *Fe PBM pipe beveling machines*
- *Promotech pipe beveling machines*
- *FCO cutting oil*
- *Mackma pipe/tube bending machines*

Content

Fe Powertools Magnetic drilling machines	4
<i>FE 30, FE 32 X, FE 36 SX, FE 36 X</i>	6
<i>FE 37 AUT, FE 50 X, FE 50 RL X, FE 60 RL X</i>	7
<i>FE 100 RL X, FE Air 40, FE Rail 36</i>	8
<i>Hole cutters</i>	9
<i>Technical drawings</i>	10
Accessories	12
<i>Pilot Pins, Hole Cutter adapters, Weldon Quick Change Tap Holders</i>	13
<i>Twist drills, Keyed drill chucks, Keyless drill chucks, Taper adapters, Weldon Reduction</i>	14
<i>Carbide burrs, Taps and Countersinks</i>	15
<i>Magnetic Chip remover, Vacuum plates, Pipe Clamp Systems, Universal drill stand</i>	16
<i>Morse tapers, Reamers and Twist drills with Weldon</i>	17
<i>Punching machines</i>	18
<i>Punch and dies</i>	19
<i>Oilfeed twist drills</i>	20
<i>Sanding Belts and Mackma Tube bending</i>	21
<i>FE Cutting and Grinding discs</i>	22
<i>FE Flap disc and Band saws</i>	23
Pipe cutting machines	24
<i>Exact 170, Exact 170 E, Exact 220 E</i>	25
<i>Exact 280 E, Exact 360 E, Exact P 400</i>	26
<i>Exact V 1000, Exact 170 Battery, Exact P 400 Battery, Exact V 1000 Battery</i>	27
<i>Sawblades Exact machines</i>	28
Beveling machines	29
<i>FE BPM 25, FE PBM 76, FE PBM 159</i>	30
<i>FE PBM 210, FE PBM 340, FE PBM 630</i>	31
<i>FEB 15/2, FEB 20, FEB 25</i>	32
<i>FEB 30/45/R25, FEB 530/545, FEB 630/645</i>	33
<i>UZ 12, UZ 50, B15 Air</i>	34
<i>B2 Air</i>	35
Lubricants and cutting oils	36

Heavy work needs powerful tools from Fe Powertools.

PROFESSIONAL DRILLING MACHINES FOR DEMANDING CONDITIONS

Fe Powertools magnetic drilling machines are for serious business. All the magnetic drilling machines come with the strongest original EIBENSTOCK motors manufactured in Germany.

Fe Powertools magnetic drilling machines are equipped with the strongest dual-coil electromagnets, have a user-friendly ergonomic design and all electronic PCB Boards come from European suppliers. The new Fe Powertools magnetic drilling machine line is specially designed so that most parts are interchangeable, including the standard, magnet and switches. All machines come with an automatic coolant system mounted cleverly on top of the machines. In the strong, standard-supplied PP box, the machine is fully protected during heavy transport.

If Fe Powertools can't help you,
nobody can.

Fe Powertools is constantly investigating the actual market situation to offer its customers the most innovative products that will get the job done quickly, easily, safely and inexpensively.





All our Fe Powertools magnetic drilling machines come in strong PP carrying boxes, complete with hex keys, pilot pins, cutting oil, safety strap and of course a user's manual and safety guidelines.



MAGNETIC DRILLING MACHINES

 <p>FEpowerTools® MADE IN GERMANY CE</p>	 <p>FEpowerTools® MADE IN GERMANY CE</p>	 <p>FEpowerTools® MADE IN GERMANY CE</p>	 <p>Made in Europe CE</p>
<h2>FE 30</h2> <p>Magnetic Drilling Machine</p>	<h2>FE 32 X</h2> <p>Magnetic Drilling Machine</p>	<h2>FE 36 SX</h2> <p>Horizontal Magnetic Drilling Machine</p>	<h2>FE 36 X</h2> <p>Magnetic Drilling Machine</p>
 <p>max. ø 30 mm</p>	  <p>max. ø max. ø 32 mm 13 mm</p>	 <p>max. ø 36 mm</p>	 <p>max. ø 36 mm</p>
<p>Machine box includes: FE machine with coolant system, safety chain, pilot pin, 0.25L cutting oil, safety guidelines and users manual.</p>	<p>Machine box includes: FE machine with coolant system, safety strap, pilot pin, 0.25L cutting oil, safety guidelines and users manual.</p>	<p>Machine box includes: FE machine with coolant system, safety chain, pilot pin, 0.25L cutting oil, safety guidelines and users manual.</p>	<p>Machine box includes: FE machine with coolant system, safety strap, pilot pin, 0.25L cutting oil, safety guidelines and users manual.</p>
<p>Motor power 1050 watt</p> <p>Spindle 19 mm (3/4") Weldon</p> <p>Hole cutter (short 30 mm) ø 12 mm - ø 30 mm (1-3/16")</p> <p>Hole cutter (long 55 mm) ø 12 mm - ø 30 mm (1-3/16")</p> <p>RPM 460 min-1</p> <p>Stroke 70 mm (3.15")</p> <p>Weight 9.9 kg (21.83 lbs)</p> <p>Magnet power 1500 kg (3304 lbs)</p> <p>Available in 230V and 110V</p>	<p>Motor power 1050 watt</p> <p>Spindle 19 mm (3/4") Weldon</p> <p>Hole cutter (short 30 mm) ø 12 mm - ø 32 mm (1-1/4")</p> <p>Hole cutter (long 55 mm) ø 12 mm - ø 32 mm (1-1/4")</p> <p>Twist drill ø 13 mm (1/2")</p> <p>RPM 460 min-1</p> <p>Stroke 160 mm (6.29")</p> <p>Weight 12 kg (26,8 lbs)</p> <p>Magnet power 1500 kg (3304 lbs)</p> <p>Available in 230V and 110V</p>	<p>Motor power 1080 watt</p> <p>Spindle 19 mm (3/4") Weldon</p> <p>Hole cutter (short 30 mm) ø 12 mm - ø 36 mm (1-7/16")</p> <p>RPM 400 min-1</p> <p>Stroke 39 mm (1.54")</p> <p>Handle position Comes standard with ratchet</p> <p>Weight 11 kg (24.2 lbs)</p> <p>Height Only 18 cm</p> <p>Magnet power 1500 kg (3304 lbs)</p> <p>Available in 230V and 110V</p>	<p>Motor power 920 watt</p> <p>Spindle 19 mm (3/4") Weldon</p> <p>Hole cutter (short 30 mm) ø 12 mm - ø 36 mm (xxxx")</p> <p>Hole cutter (long 55 mm) ø 12 mm - ø 36 mm (xxxx")</p> <p>RPM 350 min-1</p> <p>Stroke 70 mm (2-3/4")</p> <p>Weight 10 kg (21,5 lbs)</p> <p>Magnet power 1000 kg (2150 lbs)</p> <p>Available in 230V and 110V</p>
<p>Comes standard with cooling system in strong PP-box</p>	<p>Comes standard with cooling system in strong PP-box</p>	<p>Comes standard with cooling system in steel case</p>	<p>Comes standard with cooling system in strong PP-box</p>

For technical drawings and measurements see page 10 and 11

MAGNETIC DRILLING MACHINES

 <p>FEpowerTools®</p> <p>Made in Europe </p>	 <p>FEpowerTools®</p> <p> </p>	 <p>FEpowerTools®</p> <p> </p> <p>Left/ Right option</p>	 <p>FEpowerTools®</p> <p> </p> <p>Left/ Right option</p>
<h2>FE 37 AUT</h2> <p>Magnetic Drilling Machine automatic</p>	<h2>FE 50 X</h2> <p>Magnetic Drilling Machine</p>	<h2>FE 50 RL X</h2> <p>Magnetic Drilling Machine</p>	<h2>FE 60 RL X</h2> <p>Magnetic Drilling Machine</p>
 <p>max. ø 37 mm</p>	 <p>max. ø 50 mm max. ø 23 mm</p>	 <p>max. ø 50 mm max. ø 23 mm M5-M16 max. ø 50 mm</p>	 <p>max. ø 60 mm max. ø 25 mm M5-M20 max. ø 50 mm</p>
<p>Machine box includes: FE machine with coolant system, safety strap, pilot pin, 0.25L cutting oil, safety guidelines and users manual.</p>	<p>Machine box includes: FE machine with coolant system, safety strap, pilot pin, 0.25L cutting oil, safety guidelines and users manual.</p>	<p>Machine box includes: FE machine with coolant system, safety strap, pilot pin, 0.25L cutting oil, safety guidelines and users manual.</p>	<p>Machine box includes: FE machine with coolant system, safety strap, pilot pin, 0.25L cutting oil, safety guidelines and users manual.</p>
<p>Motor power 920 watt</p> <p>Spindle 19 mm (3/4") Weldon</p> <p>Hole cutter (short 30 mm) ø 12 mm - ø 37 mm (xxxx")</p> <p>Hole cutter (long 55 mm) ø 12 mm - ø 37 mm (xxxx")</p> <p>RPM 350 min-1</p> <p>Stroke 70 mm (2-3/4")</p> <p>Weight 13,5 kg (30 lbs)</p> <p>Magnet power 1000 kg (2150 lbs)</p> <p>Available in 230V and 110V</p>	<p>Motor power 1150 watt</p> <p>Spindle MT2, 19 mm (3/4") Weldon</p> <p>Hole cutter (short 30 mm) ø 12 mm - ø 50 mm (1-1/4")</p> <p>Hole cutter (long 55 mm) ø 12 mm - ø 50 mm (1-1/4")</p> <p>Twist drill ø 23 mm (7/8")</p> <p>RPM I 250 min-1 / II 450 min-1</p> <p>Stroke 160 mm (6.29")</p> <p>Weight 13 kg (26.8 lbs)</p> <p>Magnet power 1500 kg (3304 lbs)</p> <p>Available in 230V and 110V</p>	<p>Motor power 1150 watt</p> <p>Spindle MT2, 19 mm (3/4") Weldon</p> <p>Hole cutter (short 30 mm) ø 12 mm - ø 50 mm (1-1/4")</p> <p>Hole cutter (long 55 mm) ø 12 mm - ø 50 mm (1-1/4")</p> <p>Twist drill ø 23 mm (7/8")</p> <p>Tapping ø M5-M16</p> <p>Countersinking ø 40 mm (1-9/16")</p> <p>RPM (variable) I 50-250 min-1 / II 180-450 min-1</p> <p>Stroke 160 mm (6.29")</p> <p>Weight 13 kg (26.8 lbs)</p> <p>Magnet power 1500 kg (3304 lbs)</p> <p>Available in 230V and 110V</p>	<p>Motor power 1600 watt</p> <p>Spindle MT3, 19 mm (3/4") Weldon</p> <p>Hole cutter (short 30 mm) ø 12 mm - ø 60 mm (1-1/4")</p> <p>Hole cutter (long 55 mm) ø 12 mm - ø 60 mm (1-1/4")</p> <p>Hole cutter (extra long 75 mm) ø 20 mm - ø 60 mm (1-1/4")</p> <p>Twist drill ø 25 mm (1")</p> <p>Tapping ø M5-M20</p> <p>Countersinking ø 50 mm (2")</p> <p>RPM I 70-280 min-1 / II 180-580 min-1</p> <p>Stroke 160 mm (6.29")</p> <p>Weight 15 kg (33 lbs)</p> <p>Magnet power 1500 kg (3304 lbs)</p> <p>Available in 230V and 110V</p>
<p>Comes standard with cooling system in steel case</p>	<p>Comes standard with cooling system in strong PP-box</p>	<p>Comes standard with cooling system in steel case</p>	<p>Comes standard with cooling system in strong PP-box</p>

For technical drawings and measurements see page 10 and 11

MAGNETIC DRILLING MACHINES

FEpowerTools®



Left/ Right option

FE 100 RL X

Magnetic Drilling Machine



Machine box includes:

FE machine with coolant system, safety chain, pilot pin, 0.25L cutting oil, safety guidelines and users manual.

Motor power
1800 watt

Spindle
MT3, 19 mm (3/4") Weldon

Hole cutter (short 30 mm)
ø 12 mm - ø 100 mm (4")

Hole cutter (long 55 mm)
ø 12 mm - ø 100 mm (4")

Hole cutter (extra long 75/110 mm)
ø 20 mm - ø 100 mm (4")

Countersinking
ø 50 mm (2")

Reaming
ø 31.75 mm (1-1/4")

Twist drills
ø 31.75 mm (1-1/4")

Tapping
M6 - M30

RPM
I 140-140 min-1 / II 120-480 min-1

Stroke
250 mm (9.85")

Weight
27 kg (59.5 lbs)

Magnet power
3500 kg (7716 lbs)

Available in 230V and 110V

Comes standard with cooling system in strong PP-box

FEpowerTools®



FE Air 40

Magnetic Drilling Machine



Machine box includes:

FE machine with coolant system, safety chain, pilot pin, 0.25L cutting oil, safety guidelines and users manual.

Motor power
830 watt

Air
1000 L/min

Spindle
Keyless MT2-19 mm Weldon

Hole cutter (short 30 mm)
ø 12 mm - ø 35 mm (1.3")

Hole cutter (long 55 mm)
ø 12 mm - ø 35 mm (1.3")

Twist drills
ø 23 mm (7/8")

RPM
290-575 min-1

Stroke
150 mm (6.90")

Weight
17.5 kg (38.5 lbs)

Comes standard with cooling system in steel case

FEpowerTools®

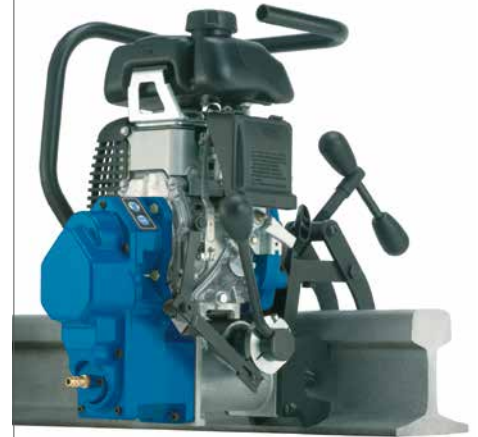

FE Rail 36

Magnetic Drilling Machine



Machine box includes:

FE machine with coolant system, pilot pin, 0.25L cutting oil, safety guidelines and users manual.

Motor power
1.5 Kw

Motor
4 stroke Honda GXH 50 (Fuel)

Spindle
19 mm (3/4") Weldon

Hole cutter (short 30 mm)
ø 17 mm - ø 36 mm Railcutter (1.4")

RPM
150-225 min-1 / 180-580 min-1

Stroke
40 mm (9.85")

Weight
21.5 kg (47.3 lbs)

On request different rail adaptors:
NP46, UIC 54, UIC 60 and all others on request.

Comes standard with cooling system in steel case



HOLE CUTTERS



HSS Annular cutters

For cutting standard steel

Article nr.	Max. Cutting depth	ø Sizes	Connection
FE 30 HSS Hole cutter	30 mm	12 - 130 mm	Weldon
FE 55 HSS Hole cutter	55 mm	12 - 130 mm	Weldon
FE 110 HSS Hole cutter	110 mm	18 - 50 mm	Weldon



TCT Tungsten Carbide Tipped Cutters

For cutting tougher materials like stainless steel and Hardox but also standard steel

Article nr.	Max. Cutting depth	ø Sizes	Connection
FET 30 TCT Hole cutter	30 mm	12 - 150 mm	Weldon/Nitto
FET 55 TCT Hole cutter	55 mm	12 - 100 mm	Weldon/Nitto
FET 75 TCT Hole cutter	75 mm	18 - 120 mm	Weldon
FET 110 TCT Hole cutter	110 mm	20 - 120 mm	Weldon
FET F35 TCT Hole cutter	35 mm	12 - 60 mm	Fein



Railcutters FETR Tungsten Carbide tipped Cutters

For cutting railbars and very tough materials

Article nr.	Max. Cutting depth	ø Sizes	Connection
FETR 30 Hole cutter	30 mm	17 - 36 mm	Weldon

TECHNICAL DRAWINGS

Magnetic Drilling Machine

FE 30

Magnetic Drilling Machine

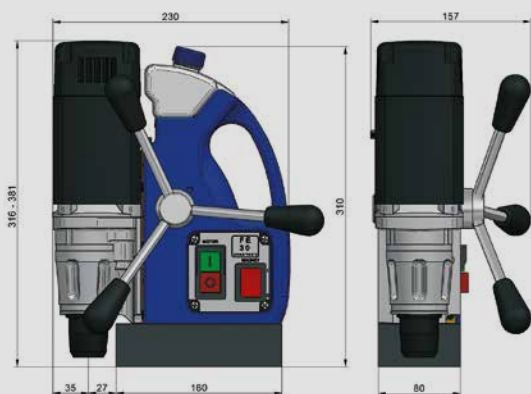

FE 32 X

Magnetic Drilling Machine

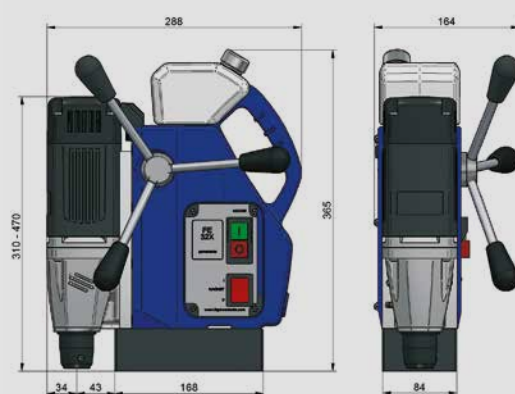

FE 36 SX

Magnetic Drilling Machine

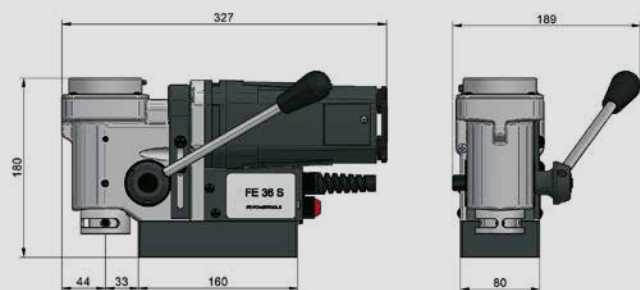

FE 36 X

Magnetic Drilling Machine

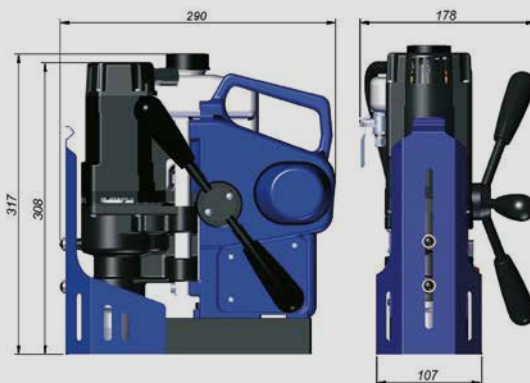

FE 37 AUT

Magnetic Drilling Machine

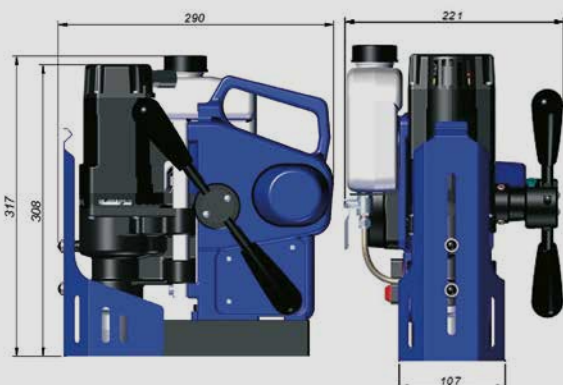

FE 50 X

Magnetic Drilling Machine

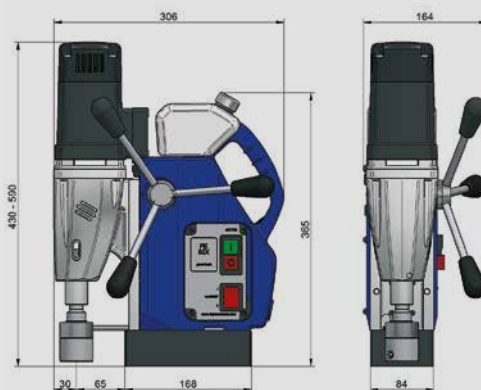

TECHNICAL DRAWINGS

Magnetic Drilling Machine

FE 50 RL X

Magnetic Drilling Machine

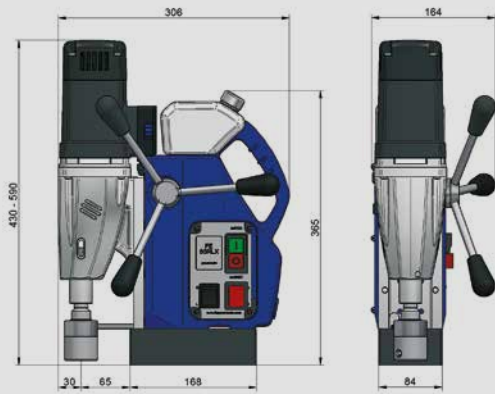

FE Air 40

Magnetic Drilling Machine

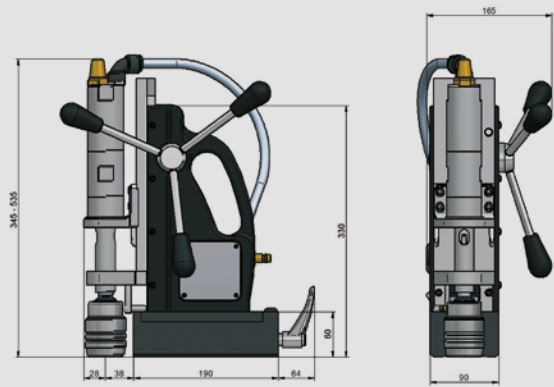

FE 60 RLX

Magnetic Drilling Machine

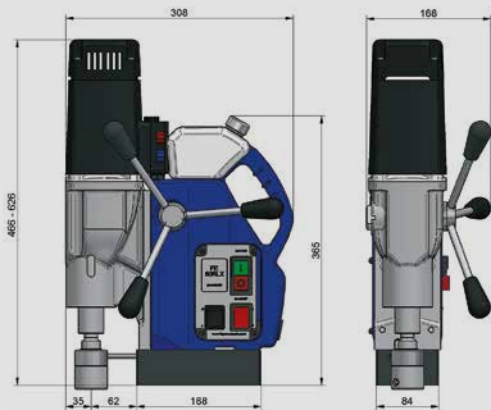

FE Rail 36

Rail Drilling Machine

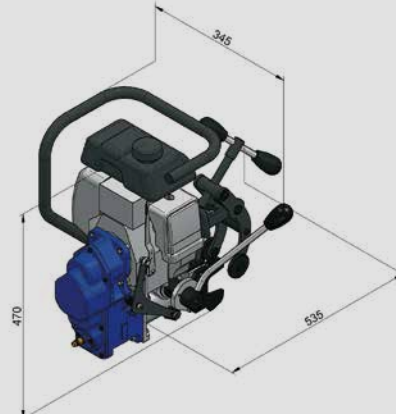

FE 100 RLX

Magnetic Drilling Machine

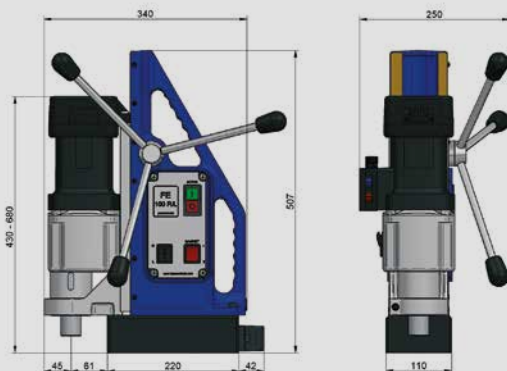

ONLY THE BEST ACCESSORIES

Better performance with Fe Powertools accessories.

For all kinds of applications, we can offer just the right accessory to make your work easy and comfortable. With the knowledge that we have gathered over decades regarding the actual working experiences of our customers, we know exactly what accessories will improve results and increase user comfort. The best materials have been used to manufacture our line of accessories. They are guaranteed for professional use. If by any chance you should lack an accessory in our catalogue, please feel free to contact us.



ACCESSORIES

Pilot Pins

The pilot pin has 3 functions: to centering the cutter, transporting the oil to the material and pushing out the slug

Article nr.	For	Cutting	Connection
FEPP 75	FE 30	∅ 12 - 60 mm	19 mm (3/4") Weldon
FEPP 90	FE 30	∅ 61 - 130 mm	31.75 mm (1-1.4") Weldon
FEPP 100	FE 55	∅ 12 - 60 mm	19 mm (3/4") Weldon
FEPP 120	FE 55	∅ 61 - 100 mm	31.75 mm (1-1.4") Weldon
FEPP 275	FE 110	∅ 18 - 50 mm	19 mm (3/4") Weldon
FEPP 75	FET 30	∅ 14 - 60 mm	19 mm (3/4") Weldon/Nitto "One-Touch"
FEPP 90	FET 30	∅ 61 - 130 mm	31.75 mm (1-1/4") Weldon
FEPP 100	FET 50	∅ 14 - 60 mm	19 mm (3/4") Weldon
FEPP 120	FET 50	∅ 61 - 100 mm	31.75 mm (1-1/4") Weldon
FEPP 245	FET 75	∅ 20 - 120 mm	19 mm (3/4") Weldon, 31.75 mm (1-1/4")
FEPP 275	FET 110	∅ 20 - 60 mm	19 mm (3/4") Weldon
FEPP 275	FET 110	∅ 61 - 120 mm	31.75 mm (1-1/4") Weldon
FEPP 96	FET F30	∅ 14 - 60 mm	18 mm Fein Quick In
FEPP 75	FET R30	∅ 17 - 36 mm	19 mm (3/4") Weldon



Hole Cutter Adapters FEHC

Article nr.	Description	Machine side	Hole cutter side
FEHCA 001	Drill Chuck Adapter	Weldon 19 mm (3/4")	1/2" x 20 NF
FEHCA 002	Adapter (including pilot pin FEPP 125)	Weldon 19 mm (3/4")	M18 x 6 x P 15
FEHCA 003	Adapter (including pilot pin FEPP 115)	Weldon 19 mm (3/4")	Fein Quick-in
FEHCA 004	Adapter (including pilot pin FEPP 107 and FEPP 125)	Fein Quick-in	Weldon 19 mm (3/4")
FEHCA 005	Adapter with Nitto shank (including pilot pin FEPP 107)	Nitto "One-Touch"	Weldon 19 mm (3/4")
FEHCA 006	Adapter for Hole Cutters with thread M16 x 1.5 (including FEPP)	Weldon 19 mm (3/4")	M16 x 1.5
FEHCA 008.50	Shank extension 50 mm	Weldon 19 mm (3/4")	Weldon 19 mm (3/4")
FEHCA 008.75	Shank extension 75 mm	Weldon 19 mm (3/4")	Weldon 19 mm (3/4")
FEHCA 008.100	Shank extension 100 mm	Weldon 19 mm (3/4")	Weldon 19 mm (3/4")



Weldon Quick Change Tap Holders FEMTE

Article nr.	Thread	Shank ∅	Square
FEMTE 001.10	M10 DIN376	7	5.5
FEMTE 001.12	M12 DIN376	9	7
FEMTE 001.14	M14 DIN376	11	9
FEMTE 001.16	M16 DIN376	12	9
FEMTE 001.18	M18 DIN376	14	11
FEMTE 001.20	M20 DIN376	16	12
FEMTE 001.22	M22 DIN376	18	14.5
FEMTE 001.24	M24 DIN376	18	14.5
FEMTE 001.27	M27 DIN376	20	16
FEMTE 001.30	M30 DIN376	22	18



ACCESSORIES



Twist Drills FE

Article nr.	Description
FE 100	HSS twist drill DIN 338 roll forged. 0.3 - 20.0 mm ascending by 0.1 mm
FE 105	HSS twist drill DIN 338 fully ground - splitpoint. 0.5 - 16.0 mm ascending by 0.1 mm
FE 106	HSS-E (Co 5) twist drill DIN 338 fully ground - splitpoint. 1.0 - 10.0 mm ascending by 0.1 mm 10.2 / 10.5 / 11 / 11.2 / 11.5 mm, 12.0 - 16.0 mm ascending by 0.5 mm
FE 103	HSS taper shank drill DIN 345 (Morse Konus). 10.0 - 50.0 mm ascending by 0.5 mm, 50.0 - 60.0 mm ascending by 1.0 mm
FE 108	HSS taper shank drill DIN 345 - Milled - Long Series. 9.0 - 30.0 mm ascending by 0.5 mm, 30.0 - 50.0 mm ascending by 1.0 mm
FE 113	HSS Twist drill DIN1897 Short Stroke fully ground 3.0-13.0 mm ascending by 0.5 mm



Keyed drill chucks FEKDC

Article nr.	Taper bore	Chuck size
FEKDC 13.001	DIN238-B16	1 - 13 mm
FEKDC 16.001	DIN238-B16	2.5 - 16 mm
FEKDC 13.002	1/2" x 20 NF	1 - 13 mm
FEKDC 16.002	1/2" x 20 NF	2.5 - 16 mm



Keyless drill chucks FEKDC

Article nr.	Taper bore	Chuck size
FEKDC 13.003	DIN238-B16	1 - 13 mm
FEKDC 16.003	DIN238-B16	3 - 16 mm
FEKDC 13.004	1/2" x 20 NF	1 - 13 mm
FEKDC 16.004	1/2" x 20 NF	3 - 16 mm



Taper adapters FEDTA

Article nr.	DIN Norm
FEDTA 001.216	DIN238-MT2/B16
FEDTA 001.316	DIN238-MT3/B16
FEDTA 001.218	DIN238-MT2/B18
FEDTA 001.318	DIN238-MT3/B18



Weldon reduction FEHCA

Article nr.	Description
FEHCA007	Reduction from 31.75 mm (1-1/4") Weldon 19 mm (3/4") Weldon

ACCESSORIES

FE 800 Carbide Burrs *Tungsten Carbide*

These are just a few from our large selection, all other sizes are available upon request. We supply all sizes and shapes.

Article nr.	Description
FE 801.1201	Carbide burr cylindrical with end cut 12 x 25 mm
FE 801.1202	Carbide burr cylindrical without end cut 12 x 25 mm
FE 802.1201	Carbide burr cylindrical radius end 12 x 25 mm
FE 803.1201	Carbide burr tree shape radius end 12 x 25 mm
FE 803.1202	Carbide burr tree shape point end 12 x 25 mm
FE 804.1201	Carbide burr conical radius end 12 x 25 mm
FE 805.1201	Carbide burr oval 12 x 25 mm



FE 200 Taps *High-quality HSS taps*

These sizes are just a few from our large program. All other sizes on request, we supply all sizes.

Article nr.	Description
FE 200.100	Machine taps HSSE form B DIN 376 M3 up to M52
FE 200.101	Machine taps HSSE form B DIN 371 M2 up to M10
FE 200.103	Machine taps HSSE form C/35° DIN 376 M3 up to M52
FE 200.104	Machine taps HSSE form C/35° DIN 371 M2 up to M100
FE 220.100080	Machine tap M8 DIN379/B Weldon
FE 220.100100	Machinetap M10 DIN379/B Weldon
FE 220.100120	Machinetap M12 DIN379/B Weldon
FE 220.100160	Machinetap M16 DIN379/B Weldon
FE220.100200	Machinetap M20 DIN379/B Weldon

Our program of taps consists of:

Inner thread: M1-M110, BSW1/16"-BSW3", BSF3/16"-BSF1", BA0-BA6, UNC No. 1 - UNC2", UNF No. 0 - UNF1.1/2", UNEF1/4"-UNEF1", G1/8"-G4", PG7-PG48, Tr10-Tr32, W19,9-W31,8, Rc1(BSPT)/16"-Rc2", RP(BSPP)/1/16"-Rp2, NPT1/16"-NPT2", NPTF1/16"-NPTF2", NPS1/16"-NPS2"

Outer thread: M1-M110, BSW1/16"-BSW3", BSF3/16"-BSF1", BA0-BA6, UNC No. 1 - UNC2", UNF No. 0 - UNF1.1/2", UNEF No. 12-UNEF1.1/2", G1/8"-G4", R(BSPT)1/*"-1.1/4", NPT1/16"-NPT2", NPTF1/8"-NPTF1", 8-UN1.1/8"-8-UN2.1/2"



FECS Countersinks *High-quality HSS countersinks*

Article nr.	Degrees	ø	Connection
FECS 19	10-19 mm	19 mm	3/4" Weldon
FECS 20,5	10-20,5 mm	20,5 mm	3/4" Weldon
FECS 25	10-25 mm	25 mm	3/4" Weldon
FECS 30	10-30 mm	30 mm	3/4" Weldon
FECS 40	10-40 mm	40 mm	3/4" Weldon
FECS 50	15-55 mm	55 mm	3/4" Weldon



FE 150.100104	Countersink HSS	10,4 mm 90°	DIN335C
FE 150.100124	Countersink HSS	12,4 mm 90°	DIN335C
FE 150.100165	Countersink HSS	16,5 mm 90°	DIN335C
FE 150.100190	Countersink HSS	19.0 mm 90°	DIN335C
FE 150.100205	Countersink HSS	20.5 mm 90°	DIN335C
FE 150.100250	Countersink HSS	25.0 mm 90°	DIN335C
FE 150.100310	Countersink HSS	31.0 mm 90°	DIN335C

Article nr.	Description
FECSSET 01	FEC Set Countersink Set (6) High Speed Steel: 6.3, 8.3, 10.4, 12.4, 16.5, 20.5 mm



ACCESSORIES



FECD 004



FECD 003



FECD 005



FECD 006



FEMC 001



FECD002

Article nr.	Product	Description
FEMC 001	Magnetic Chip Remover	Clean your workspace
FECD 003	Vacuum Plate Round	For non magnetic materials, clamping system with vacuum motor
FECD 004	Vacuum Plate Oval	For non magnetic materials, clamping system with vacuum motor. 2 suction surfaces
FECD 006	Pipe Clamp System	For FE 100 R/L (For pipes 150-500 mm). Easily cut holes in pipes and tubes
FECD 005	Pipe clamp system	For FE 30, 32x, 32 R/Lx, 50x and 50 R/Lx (For pipes: 80 - 250 mm). Easily cut holes in pipes and tubes
FECD 002	Universal drill stand (ø 43 mm)	For commercially available handdrills with a collar ø 43 mm
FECD 002.1	Clamping vice 100 mm	
FECD 002.2	Screws for T-slots	
FECD 002.3	Hexagon nut with collar	

ACCESSORIES

Morse Tapers – Weldon connections FEMT

Article nr.	Morse taper	Hole cutter shank	Operation	Lubrication
FEMT219	MT 2	19 mm (3/4") Weldon	Manual	Manual
FEMT319	MT 3	19 mm (3/4") Weldon	Manual	Manual
FEMT419	MT 4	19 mm (3/4") Weldon	Manual	Manual
FEMT232	MT 2	32 mm (1-1/4") Weldon	Manual	Manual
FEMT332	MT 3	32 mm (1-1/4") Weldon	Manual	Manual
FEMT432	MT 4	32 mm (1-1/4") Weldon	Manual	Manual
FEMTA2C	MT 2	19 mm (3/4") Weldon	Quick connect	Automatic
FEMTA3C	MT 3	19 mm (3/4") Weldon	Quick connect	Automatic
FEMT219C	MT 2	19 mm (3/4") Weldon	Manual	Automatic
FEMT319C	MT 3	19 mm (3/4") Weldon	Manual	Automatic
FEMTC419C	MT 4	19 mm (3/4") Weldon	Manual	Automatic
FEMTC232C	MT 2	32 mm (3/4") Weldon	Manual	Automatic
FEMTC332C	MT 3	32 mm (3/4") Weldon	Manual	Automatic
FEMTC432C	MT 4	32 mm (3/4") Weldon	Manual	Automatic



Reamers *All reamers also available with Hexagon connection*

Article nr.	Max. ø	Max. diepte	from ø	connection	Length
FE190.0140	14.0 mm	52 mm	7.0 mm	Weldon	140 mm
FE190.0180	19.0 mm	61 mm	9.5 mm	Weldon	165 mm
FE190.0200	20.0 mm	62 mm	11.0 mm	Weldon	178 mm
FE190.0220	22.0 mm	62 mm	13.0 mm	Weldon	178 mm
FE190.0240	24.0 mm	63 mm	15.0 mm	Weldon	178 mm
FE190.0260	26.0 mm	67 mm	16.0 mm	Weldon	178 mm
FE190.0280	28.0 mm	67 mm	18.5 mm	Weldon	178 mm
FE190.0300	30.0 mm	64 mm	21.0 mm	Weldon	178 mm
FE190.0320	32.0 mm	64 mm	22.5 mm	Weldon	178 mm
Article nr.	Connection				
FE190.0001	Reamers 1/2" (Impact wrench) - 19 mm Weldon				
FE190.0002	Reamers 3/4" (Impact wrench) - 19 mm Weldon				



Adapter Weldon connection for twistdrills FE

Article nr.	Connection
FETD 06	Adapter Weldon – ø 6.0 mm (including ø 6.0 mm twist drill)
FETD 065	Adapter Weldon – ø 6.5 mm (including ø 6.5 mm twist drill)
FETD 068	Adapter Weldon – ø 6.8 mm (including ø 6.8 mm twist drill)
FETD 07	Adapter Weldon – ø 7.0 mm (including ø 7.0 mm twist drill)
FETD 075	Adapter Weldon – ø 7.5 mm (including ø 7.5 mm twist drill)
FETD 08	Adapter Weldon – ø 8.0 mm (including ø 8.0 mm twist drill)
FETD 085	Adapter Weldon – ø 8.5 mm (including ø 8.5 mm twist drill)
FETD 09	Adapter Weldon – ø 9.0 mm (including ø 9.0 mm twist drill)
FETD 095	Adapter Weldon – ø 9.5 mm (including ø 9.5 mm twist drill)
FETD 10	Adapter Weldon – ø 10.0 mm (including ø 10.0 mm twist drill)
FETD 105	Adapter Weldon – ø 10.5 mm (including ø 10.5 mm twist drill)
FETD 11	Adapter Weldon – ø 11.0 mm (including ø 11.0 mm twist drill)
FETD 115	Adapter Weldon – ø 11.5 mm (including ø 11.5 mm twist drill)
FETD 12	Adapter Weldon – ø 12.0 mm (including ø 12.0 mm twist drill)
FETD 125	Adapter Weldon – ø 12.5 mm (including ø 12.5 mm twist drill)
FETD 13	Adapter Weldon – ø 13.0 mm (including ø 13.0 mm twist drill)



PUNCHING MACHINES

Double action - fully automated process of punching and return, Wide range of hole diameters up to 27mm, Modern construction, Intelligent control system with inching and automatic load detection, Mode indicator light, Protection against accidental start-up, Easy to handle in unusual positions, All connecting ports located at the back, Wide range of specially shaped punches and dies, Patent-pending, compact and moveable hydraulic power pack, Unique Gantry Punching Station increases both productivity and operator's comfort.

FE 60 HP

Portable Double Action Hydraulic Puncher



Portable Double-Action Hydraulic Puncher Technical Specification	
Max. throat depth	60 mm
Max. hole	ø 27 mm
Max. oblong hole	25 x 18 mm
Punching time	5 Sec.
Max. plate thickness	13 mm
Punching power	35 Ton
Working pressure	700 bar
Weight	20 Kg

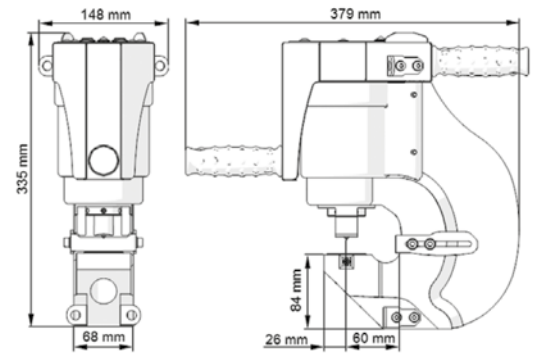

FE 110 HP

Portable Double Action Hydraulic Puncher



Portable Double-Action Hydraulic Puncher Technical Specification	
Max. throat depth	110 mm
Max. hole	ø 27 mm
Max. oblong hole	25 x 18 mm
Punching time	8 Sec.
Max. plate thickness	16 mm
Punching power	47 Ton
Working pressure	700 bar
Weight	35 Kg

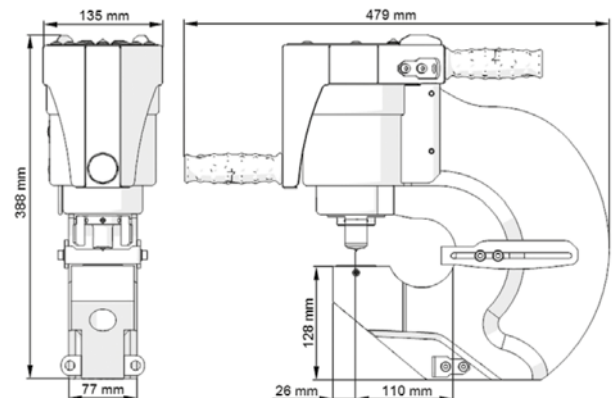

PUNCH AND DIES

FE 700 HPP

Double Action Powerpack



Double Action Powerpack	
Power supply	230V/50 Hz
Motorpower	1500 W
Working pressure	700 bar
Oil capacity	10 L

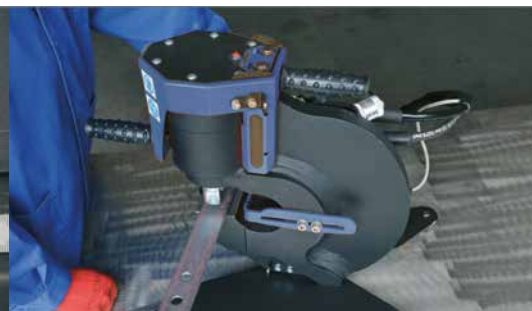

Punches and Dies

All the punches and dies distributed by Fe Powertools are produced in Europe. Our punch and die factory specializes in manufacturing all kinds of punches and dies for the most well-known brands. These punches and dies are for universal use. The European factory has over 50 years of experience in producing these tools and is continuously innovating to achieve the highest quality tooling within a lightning-fast production time.

We offer universal punches and dies for all kinds of machines, including: Mubea, Kingsland, Peddinghaus, Geka, Nitto, Sunrise, Alfra and Durma.

For more information check our website and pricelist.



OILFEED TWIST DRILLS

Chipbreaker drill in action

Standard drill in action

This outstanding development increases drill-cutting efficiency by means of greatly improved chip control. A chipbreaker rib is positioned along the length of the flutes. It curls and breaks long, chip-forming material into small, manageable chips for easier evacuation. This prevents chips from clogging the flutes, as the smaller chips flow freely along the flutes. The Chipbreaker drill thus cuts more freely than standard drills.



Oil Tube Chipbreaker

Chipbreaker Drills

Chipbreaker Coolant-Fed Drills

The benefits of providing coolant internally, directly to the drill-cutting edge, include higher cutting speeds (reduced cutting times by up to 75%), higher feed rates, longer tool life (3 to 10 times), and less frequent resharpener. In addition, these drills provide a superior finish. The coolant assists in clearing chips from the drill point and its pressure forces the swarf along the flutes of the drill, facilitating drilling to greater depths without repeated withdrawal to clear swarf.

Coolant tubes or holes are located away from the drill web, and they do not affect web strength. Both variants connect to all coolant systems.



Coolant Feed styles



Oil Tube Chipbreaker

Oilfeed twist drills Chipbreaker

M2 material (HSS)

Fe Chipbreaker drills are manufactured from M2 standard High Speed Steel material. M2 products have a black oxide steam-tempered finish. The conventional Chipbreaker drill point angle is 118°, which is suitable for the majority of high-performance applications. Upon request we can regrind the points to 170°. Coolant can be transported axially or radially.

Oilfeed twist drills Chipbreaker

Article nr.	max.ø	coolant	connection
FE790.0120	12 mm	Axial/radial	MT3
<i>Ascending 0.5 mm</i>			
FE790.0275	27.5 mm	Axial/radial	MT3
<i>Ascending 0.5 mm</i>			
FE790.0280	28 mm	Axial/radial	MT4
<i>Ascending 0.5 mm</i>			
FE790.0440	44 mm	Axial/radial	MT4



SANDING BELTS AND TUBE BENDING MACHINES

FE Sanding belts

For most types of steel, including high-alloyed steels, Fe Powertools has the best sanding belts with high cutting capacity. The sanding belts are equipped with a self-sharpening ceramic grain, which is the latest innovation in the field of machining. The back of the sanding belts is made of polyester so that it is stronger and has a longer life time under an average or high working pressure with an average to hard sanding contact.

Available in grids : 36-40-60-80-100-120.
Once you have tried this high-quality belt,
you will never use another.

FEpowerTools®



Made in Europe

Mackma tube bending machines

Mackma tube-bending machines from Italy are the hottest new generation machines in the market. Where other manufacturers stop with innovation, the Mackma factory seizes the opportunity to develop high-end tube-bending machines that fulfill all the wishes of today's tube-bending users. With this extended Mackma program, we offer you the possibility to bend tubes and pipes to the left or right. The patented reversible die holder was designed by Mackma, and it makes bending under the head possible as well. All machines are supplied with the most up-to-date control systems, which can be programmed to perform up to 900 specific bending programs. Thanks to the strong inverter-controlled motor, these high-tech bending machines have low energy consumption. Mackma offers a standard 2-year warranty.

MACKMA
 GRUPPO MASSARO

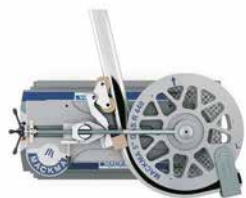

Left bending



Right bending



Under the head bending

CUTTING DISCS

FE Cutting discs

The high-quality FE Abrasives product range allows you to decrease your machining operation costs due to the products' unprecedented lifetime and minimal cutting time. FE Abrasives have a highly innovative but constant production cycle. The FE brand name refers to top Quality. The promise of product quality is not unique, but FE dares to go beyond a promise:

- FE guarantees Top quality
- FE will cut your costs using patented innovations

The fully automated production cycle is controlled by sophisticated electronic instruments. The tunnels generate a precise temperature that gradually increases up to 180° C. The consistency of this cycle ensures perfect thermal treatment, resulting in optimal performance and polymerization of the discs. Research and development is sincerely FE's biggest passion. With this continual investment FE strives for continuous improvement of its products. This is fully reflected in our latest patented product innovations:

- High material machining and less material loss
- Fast cutting
- Very stable and low-vibration
- Burr-free cutting
- Clear and clean cut
- Less noise and dust
- Less energy consumption

Article nr.	Description
FE 300.125.100	cutting disc for Inox/stainless steel 125 x 1.0 x 22.23mm
FE 301.125.100	cutting disc for metal 125 x 1.0 x 22.23mm



FE Grinding discs

Fe Powertools grinding discs Depressed Center Grinding Wheels are made for angle grinding applications including weld grinding, beveling, snagging, and other surface preparation jobs requiring moderate to heavy stock removal. The 'saucer' shape allows the operator to aggressively grind at angles less than 15 degrees, improving operator comfort. The concave shape also provides wider surface contact for grinding broad surfaces. Wheels are 6.4 MM (1/4") thick.

Article nr.	Description
FE 311.125.640	grinding disc for metal and Inox 125 x 6.4 x 22.23mm



FLAP DISCS AND BAND SAWS

FE Flap discs

You no longer have to make a calculation or test our flap discs, that we have already done for you. The FE flap discs have a high cutting capacity and retain grinding power. With our discs you do not have to exert extra hard pressure on the workpiece, which makes it much easier for the user to work. It is not only a long life which determines whether a disc is good but also determines how much material can be chipped and how fast it goes. The cheapest flapdisc in purchase is never the most economical drive in the total picture.

Article nr.	Description
FE 315.124.040	Size 125 x 22 grid 40 zircomium max RPM 12.200 packing 10pcs/ carton
FE 315.124.060	Size 125 x 22 grid 60 zircomium max RPM 12.200 packing 10pcs/ carton
FE 315.124.080	Size 125 x 22 grid 80 zircomium max RPM 12.200 packing 10pcs/ carton



SWORD Band saw blades

Band saw blades offered by SWORD are manufactured in accordance to ISO 9001 procedure. Manufacturer's brand guarantees highest quality. Since 2002, SWORD has had its own line of specially selected products sold under SWORD-MASTER brand name, manufactured by world-famous producers and delivered to SWORD for distribution under its brand. In order to ensure consistently high product quality, SWORD cooperates with the Gdańsk University of Technology where each batch of band saw blades is tested for blade, frame and back hardness as well as setting and rake angles.

Sword Master band saws, all sizes available, fast deliveries, razor-sharp prices. Let us know what you need and we offer you the best quality for the best price.



SWORD Band saw blades Eco Line

Product	Description
Sword Master A	The widest range of available tooth pitches and widths
Sword Master AP	Reinforced tooth back, high tooth chipping resistance, Wider set
Sword Master 3D Universal	Three tooth shapes on one blade, the widest range of applications, for cutting either solid sections or tubes and profiles

SWORD Band saw blades Red Line

Product	Description
Sword Master X-Treme	Aggressive M42 saw blade for high-rate production cutting
Sword Master Super	Standard M42 blade of a wide range of basic applications
Sword Master Profile max	Special M42 saw blade for cutting of all kinds of tubes, shapes and profiles

SWORD Band saw blades Specials

Product	Description
Sword Master P71-C	Efficient cutting of difficult to cut materials
Sword Master M51-H	High performance sawing of large, difficult to cut metals

PIPE CUTTING MACHINES FOR THE PRO



The Original
Pipe Cutting System
made by Exact Tools

Designed in Finland

The Exact system: innovations that render pipe handling effortless, accurate and fast

Over the last ten years, Exact has developed a number of modern tools for pipe cutting, finishing and processing. Innovative products from Exact raise the pipe working efficiency to an entirely new level.

The Exact system is suitable for all pipes and materials

Exact pipe cutters are suitable for all kinds of pipe materials; a single machine allows cutting pipes of greatly differing sizes. Pipe cutting is significantly faster as compared to traditional methods. The resulting surfaces are precise and of uniform quality – the pipes are ready for joining right away.

Exact pipe cutters can be used almost anywhere, since in most countries they are approved for indoor use – for example, as compared to angle grinders, the fire hazards are substantially lesser.



exact
Pipe Cutting System

Exact pipe cutters are easy to move around and effortless to use, for it is not necessary to support the device while cutting. Since the cutting is fast and does not require strength, the physical work strain is very low.

The ergonomic design of Exact pipe cutters allows avoiding accidents at work and the related absences. Moreover, the risk of developing work strain-related maladies is reduced.

EXACT 170

Pipe cutting Machine

EXACT 170 E

Pipe cutting Machine

EXACT 220 E

Pipe cutting Machine

exact
Pipe Cutting System



Includes: PipeCut 170 pipe saw, TCT 140 blade, shoulder bag, pipe support (4pc), instructions, hex keys 5 mm & 2 mm, DVD-video.

Motor power
1010 watt

Voltage
220-240 V

Range of use
ø 15 mm - ø 170 mm

Max. pip wall
6 mm steel / 14 mm plastic

Suitable for
All materials

No-load speed
4000 r/min

Weight
5.7 kg

Blade diameter
140 mm

Mounting bore
62 mm

exact
Pipe Cutting System



Includes: PipeCut 170E pipe saw, TCT 140 blade, shoulder bag, pipe support (4pc), instructions, hex keys 5 mm & 2 mm, DVD-video

Motor power
1200 watt

Voltage
220-240 V

Range of use
ø 15 mm - ø 170 mm

Max. pip wall
8 mm steel / 14 mm plastic

Suitable for
All materials

No-load speed
1600 - 3500 r/min

Weight
5.7 kg

Blade diameter
140 mm

Mounting bore
62 mm

exact
Pipe Cutting System



Includes: PipeCut 220E pipe saw, TCT 140 blade, shoulder bag, pipe support (4pc), instructions, hex keys 5 mm & 2 mm, DVD-video.

Motor power
1200 watt

Voltage
220-240 V

Range of use
ø 15 mm - ø 220 mm

Max. pip wall
8 mm steel / 14 mm plastic

Suitable for
All materials

No-load speed
1600 - 3500 r/min

Weight
6 kg

Blade diameter
140 mm

Mounting bore
62 mm



EXACT 280 E

Pipe cutting Machine

exact
Pipe Cutting System



Includes: PipeCut 280E pipe saw, TCT 140 blade, shoulder bag, pipe support (4 pcs), instructions, hex keys 5 mm & 2 mm, DVD-video.

Motor power
1750 watt

Voltage
220-240 V

Range of use
ø 40 mm - ø 280 mm

Max. pip wall
10 mm steel / 38 mm plastic

Suitable for
All materials

No-load speed
1= 2900 r/min 2= 3900 r/min

Weight
9 kg

Blade diameter
165 mm

Mounting bore
62 mm

EXACT 360 E

Pipe cutting Machine

exact
Pipe Cutting System



Includes: PipeCut 360E pipe saw, TCT 165 blade, shoulder bag, pipe supports 2 single 1 double, instructions, hex keys 5 mm & 2 mm, DVD-video.

Motor power
1750 watt

Voltage
220-240 V

Range of use
ø 75 mm - ø 360 mm

Max. pip wall
10 mm steel / 38 mm plastic

Suitable for
All materials

No-load speed
1= 2900 r/min 2= 3900 r/min

Weight
13.5 kg

Blade diameter
165 mm

Mounting bore
62 mm

EXACT P 400

Pipe cutting Machine

exact
Pipe Cutting System



Includes: PipeCut P400 pipe saw, TCT P150 blade, cut & bevel blade, pipe supports 2 single 1 double, shoulder bag, instructions, hex key 5 mm, DVD-video.

Motor power
1010 watt

Voltage
220-240 V

Range of use
ø 100 mm - ø 400 mm

Max. pip wall
25 mm plastic / 22 mm cut & bevel

Suitable for
Plastic pipes

No-load speed
4000 r/min

Weight
6 kg

Blade diameter
148 / 150 mm

Mounting bore
62 mm

ALL EXACTTOOLS PIPE CUTTING MACHINES COME WITH:

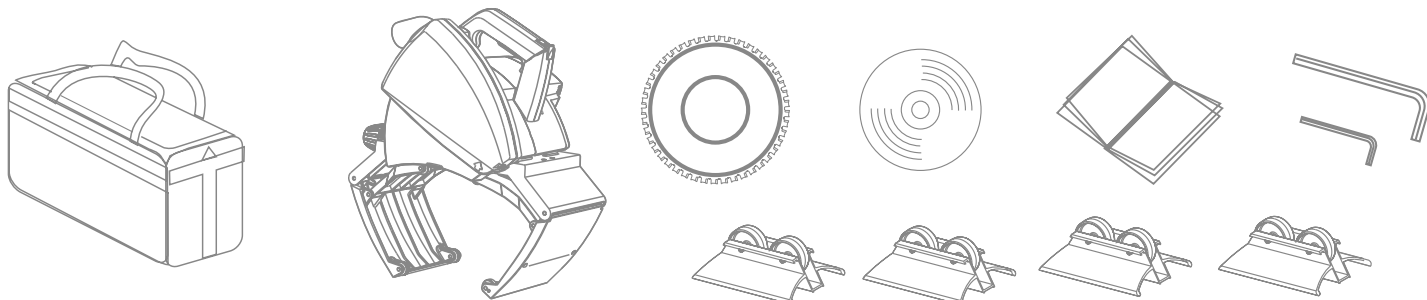

EXACT V 1000

Pipe cutting Machine

exact
Pipe Cutting System



Includes: PipeCut V1000 pipe saw, Cermet V155 blade, shoulder bag, instructions, hex keys 5 mm & 2 mm, DVD-video.

Motor power
1010 watt

Voltage
220-240 V

Range of use
ø 75 mm - ø 1000 mm

Max. pip wall
1.5 mm Spiral / Seam. 6 mm

Suitable for
Ventilation pipes

No-load speed
4000 r/min

Weight
6 kg

Blade diameter
155 mm

Mounting bore
65 mm



EXACT 170 Battery

Pipe cutting Machine

Includes: PipeCut 170 Battery pipe saw, Cermet 140 thin blade, shoulder bag, 2x 18V 4.0 Li-on batteries & charger, pipe support (4pc), instructions, hex keys 5 mm & 2 mm, DVD-video.

Battery	18 V
Range of use	ø 15 mm - ø 170 mm
Max. pipe wall	6 mm steel / 14 mm plastic
Suitable for	All materials
No-load speed	3500 r/min
Weight	6 kg
Blade diameter	140 mm
Mounting bore	62 mm

exact
Pipe Cutting System



EXACT P 400 Battery

Pipe cutting Machine

Includes: PipeCut P400 Battery pipe saw, TCT P150 blade, cut & bevel blade, pipe supports (4pc), shoulder bag, 2 x 18V 4.0 Li-on batteries & charger, instructions, hex key 5 mm, DVD-video.

Battery	18 V
Range of use	ø 100 mm - ø 400 mm
Max. pipe wall	25 mm Plastic / 22 mm cut & bevel
Suitable for	Plastic pipes
No-load speed	3500 r/min
Weight	7 kg
Blade diameter	148 / 150 mm
Mounting bore	62 mm

exact
Pipe Cutting System



EXACT V 1000 Battery

Pipecutting Machine

Includes: PipeCut V1000 Battery pipe saw, Cermet V155 blade, shoulder bag, 2x 18V 4.0 Li-on batteries & charger, instructions, hex key 5 mm, DVD-video.

Battery	18 V
Range of use	ø 75 mm - ø 1000 mm
Max. pipe wall	1.5 mm Sheet / Seam. 6 mm
Suitable for	Ventilation pipes
No-load speed	3500 r/min
Weight	7 kg
Blade diameter	155 mm
Mounting bore	65 mm

exact
Pipe Cutting System



SAWBLADES EXACT MACHINES



exact
Pipe Cutting System

Blades & discs 140 / 165 / Special blades

Article nr.	ø	Bore	Kerf	Body	Teeth	For Material	Suitable with
TCT 140	140	62	1.8	1.4	46	Steel, copper, plastics	PC 170, 170E, 220E
TCT Z140	140	62	1.8	1.4	38	Steel, copper, plastics	PC 170, 170E, 220E
Cermet 140	140	62	1.8	1.4	46	Steel, stainless steel, copper, plastics	PC 170, 170E, 220E
Cermet X140	140	62	1.8	1.4	46	Steel, stainless steel, copper, plastics	PC 170, 170E, 220E
Cermet 140 Thin	140	62	1.4	1.2	46	Steel, stainless steel, copper, plastics	PC 170 Battery
Diamond X140	140	62	2.7	1.5	x	Cast iron, Ductile (ondular cast iron)	PC 170, 170E, 220E
Alu 140	140	62	2.5	1.8	36	Aluminium	PC 170, 170E, 220E

Article nr.	ø	Bore	Kerf	Body	Teeth	For Material	Suitable with
TCT 165	165	62	1.8	1.4	52	Steel, copper, plastics	PC 280E, 360E
Cermet 165	165	62	1.8	1.4	52	Steel, stainless, copper, plastics	PC 280E, 360E
Cermet X165	165	62	1.8	1.4	52	Steel, stainless, copper, plastics	PC 280E, 360E
Diamond X165	165	62	2.7	1.5	x	Cast iron, ductille (nodular cast iron)	PC 280E, 360E
Alu 165	165	62	2.5	1.8	42	Aluminium	PC 280E, 360E
TCT P165	165	62	1.8	1.4	40	Plastics (PE, PP, PVC, etc)	PC 280E, 360E

Article nr.	ø	Bore	Kerf	Body	Teeth	For material	Suitable with
Cermet V155	155	65	1.6	1.4	58	Thin wall ventilation pipes	PC V1000, V1000 Battery
TCT P150	150	62	1.8	1.4	40	Plastics (PE, PP, PVC, etc)	PC P400, P400 Battery
Cut + bevel	148	62	2\30		40\8	Plastics (PE, PP, PVC, etc)	PC P400, P400 Battery
Cut + bevel diamond	140	62	3.3	2	x	Cast iron, plastics	PC Cut+bevel 170E, Cut+bevel 170 Battery

BEVELING MACHINES FOR PIPE, PLATE AND FINISHING



The FE PBM range of pipe beveling machines for mechanical weld preparation and orbital welding makes pipe beveling jobs easier to complete on-site or in the workshop. The pipe beveling machine is affixed to the pipe with an inside or outside clamping device. The pipe beveling machine is operated by one worker, who gives a manual feed to the pipe beveling machine with a lever. One cutter is attached to the blade holder.

In general, for the weld preparation of heavy wall pipes the weld edge end has to be beveled in a 0°, 30°, 37.5° outside or j-shape (inside 15°). Most companies use a heavy grinder for this work. This takes a long time, is not precise and creates terrible working conditions for the worker. Dust, vibrations and noise physically harm the worker. Low quality weld preparation reduces the quality of the welding junction and long preparation time increases production costs.

All FE PBM pipe beveling machines are available with an electrical or pneumatic drive. Special pipe beveling tools for a wide range of bevel applications are available. Pipe-end preparation is also necessary for orbital welding, to achieve the best pipe weld edge preparations with outside beveling and inside beveling.

FE PBM 25

Pipe beveling Machine



CE

FE PBM 76

Pipe beveling Machine



CE

FE PBM 159

Pipe beveling Machine



CE

Supplied in steelcase

Driven	Bosch motor
Power supply	220-240 V 50/60Hz
Motor power	850 watt
Clamping range (ID)	16 - 25
Working range (OD)	1" - (33.4 mm)
Wall thickness max.	< 8 mm
Rotation speed	48 MIN-1
Working weight	8 kg
Shipping weight	16 kg
Packing size	540x410x170 mm

Supplied in steelcase

Driven	Bosch motor
Power supply	220-240 V 50/60Hz
Motor power	850 watt
Clamping range (ID)	25 - 76
Working range (OD)	3" - (88.9 mm)
Wall thickness max.	< 15 mm
Rotation speed	48 MIN-1
Working weight	9 kg
Shipping weight	16 kg
Packing size	540x410x170 mm

Supplied in steelcase

Driven	Bosch motor
Power supply	220-240 V 50/60Hz
Motor power	1000 watt
Clamping range (ID)	16 - 159
Working range (OD)	6" - (168.28 mm)
Wall thickness max.	20 mm
Rotation speed	38 MIN-1
Working weight	17 kg
Shipping weight	31 kg
Packing size	560x550x250 mm



Clamping keys for different pipe diameters



Cutters

FE PBM 210

Pipe beveling Machine



CE

FE PBM 340

Pipe beveling Machine



CE

FE PBM 630

Pipe beveling Machine

FEpowerTools®



CE

Supplied in steelcase

Driven	Electric
Power supply	220-240 V 50/60Hz
Motor power	1200 watt
Clamping range (ID)	65 - 210
Working range (OD)	8" - (219.08 mm)
Wall thickness max.	< 20 mm
Rotation speed	24 MIN-1
Working weight	28 kg
Shipping weight	44 kg
Packing size	650x280x250 mm



Supplied in steelcase



Driven	Electric
Power supply	220-240 V 50/60Hz
Motor power	1500 watt
Clamping range (ID)	145 - 340
Working range (OD)	14" - (355.6 mm)
Wall thickness max.	< 20 mm
Rotation speed	20 MIN-1
Working weight	48 kg
Shipping weight	70 kg
Packing size	830x430x410 mm

Supplied in steelcase

Motor power	1430 watt
Clamping range	280 - 600 mm
Max. external diameter	300 - 630 mm
Max. wall thickness	15 mm
Pneumatic capacity	2210 watt
Feed length	54 mm
Rotation speed	10 rev/min
Weight	75 kg

Cutters for FE PBM inside pipe beveler

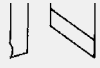
Cutter	Art No.	Description	
Plain cutter	FECI 7.0001	Plain 0°	
Bevel cutter	FECI 7.0003	Bevel 30°	

Cutter	Art No.	Description	
Bevel cutter	FECI 7.0004	bevel 37,5°	
Interior bevel cutter	FECI 7.0002	bevel 15°	

FEB 15/2

Beveling Machine

FEpowerTools®



Supplied in strong steel carrying box with all needed accessories and clear manual and safety instructions.

Motor power
2200 watt

Minimal hole diameter of countersinking
40 mm (1.57")

RPM
1800-5850 rpm

Bevel angle (depending on milling head)
22.5°, 30°, 37.5°, 45°, 55°, 60°

Rounding edges
R2, R3, R4, R5

Maximum bevel width
16 mm

Weight
10 kg (22 lbs)

Power supply
220-240 V / 50-60 Hz or 110-120V / 60Hz

Strong, portable, and very handy, this beveling machine is designed for milling edges of plates and pipes made of steel, aluminum alloys, brass, or plastic. Depending on the chosen milling head, the machine enables beveling angles of 22.5°, 30°, 37.5°, 45°, 55° or 60°. Each milling head uses 5 indexable cutting inserts. There is one milling head for each beveling radius, which enables the beveling of edges with a radius of 2, 3, 4 or 5 mm with the use of 4-sided indexable R2, R3, R4 or R5 cutting inserts. The FEB 15/2 is equipped with a continuous bevel width adjustment, overload protection and electronic speed control for use on a variety of materials.

FEB 20

Beveling Machine

FEpowerTools®



Supplied in strong steel carrying box with all needed accessories and clear manual and safety instructions.

Motor power
1100 watt

RPM
2850 min-1

Max. Bevel
20 mm (0.79")

Angle Setting
15° - 60° stepless variable

Weight
22 kg (48.5 Lbs)

Thermo protection

Machine FEB 20 comes with 2 cutting plate holders. In each holder you need 6 cutting plates which can be used on 4 sides.



FEB 25

Beveling Machine

FEpowerTools®



Supplied in strong steel carrying box with all needed accessories and clear manual and safety instructions.

Motor power
1100 watt

RPM
2850 min-1

Angle Setting
15° - 60° variable

Safety
Automatic overload cutout

Maximum bevel width
15 mm

Weight
22 kg

Tools

Arbor milling cutter, double-row with 10 sintered carbide reversible cuttingplates



FEB 30/ 45/ R25

Beveling Machine

FEB 530/ 545

Beveling Machine

FEB 630/ 645

Beveling Machine

FEpowerTools®



FEB 30 30° FEB R25 (R 2.5)
FEB 45 45°

Motor power
1500 watt

Speed
6000 min-1

Max. bevel width
0-5 mm

Angle Setting
30°

Weight
4,6 kg (10.14 Lbs)

Cutting plate holders are interchangeable. Thermo protection.

FEpowerTools®



FEB 530 30° FEB 545 45°

Motor power
1800 watt

Speed
1850 – 3350 min-1

Max. bevel width
0-12 mm

Angle Setting
30° / 45°

Weight
9,3 KG (20,04 Lbs)

Cutting plate holders are interchangeable. Thermo protection.

FEpowerTools®



FEB 630 30° FEB 645 45°

Motor power
2300 watt

Speed
1600 – 3000 min-1

Max. bevel width
0-15 mm

Angle Setting
30° / 45°

Weight
10,2 KG (21,98 Lbs)

Cutting plate holders are interchangeable. Thermo protection.

Cutting plates and holders for FEB 30, FEB 45 and FEB R25

High-quality Hardmetal cutting plates for most applications.

Article nr.	Connection
FECI2.001	CUTTING PLATE FEB 30 – FEB 45
FECI2.002	CUTTING PLATE FEB R25 (Radius 2,5)
FECI10.0001	CUTTING PLATE FEB 530/545/630/645
FECH2.0001	CUTTING PLATE HOLDER FEB 30
FECH2.0002	CUTTING PLATE HOLDER FEB 45
FECH2.0003	CUTTING PLATE HOLDER R25



UZ 12

Beveling Machine



UZ12 ULTRALIGHT creates welding-ready bevels on linear plates of any shearable material, including iron, steel (up to 60kg/mm² or 85,000lbs/in²), stainless steel, brass, copper and aluminum. It cuts bevels from 3 to 35mm in thickness, with a minimum plate width of 60 mm and minimum plate length of 60mm.

Max. width of bevel	12 mm
Bevel angle	30° - 50° variable
Thickness material	3 - 35 mm
Motor	400 watt
RPM	2800 min-1
Speed	180 cm / min
Weight	30 kg
Manipulator	Optional



Full automatic bevellingmachine

UZ 50

Beveling Machine



The beveler UZ 50 Triumph - very efficient, unique double sided beveling machine for steel, stainless steel, HARDOX, DOMEX and aluminium (max. width of bevel 62 mm) 3 BEVELERS IN ONE, fully automatic.

Max.width of bevel	62 mm
Bevel angle	15° - 60° variable
Thickness material	7 - 70 mm
Motor milling	4000 watt / 400V / 3 phases/ 50 Hz
Motor automatic feeding	2 engine 120 watt
Speed	183 cm / min
Weight	175 kg
Manipulator	Standard
Working table	Optional



Full automatic bevellingmachine

B15 Air

Beveling Machine



Pneumatic Hand Beveler with huge power for straight edges, contours, boreholes, radius. The beveler is designed and produced in Europe and brings a new high ergonomics design and huge power for every day beveling. Aluminum alloy body engine, Hardox support plate, milling head and inserts designed especially for hand beveler.

Power	2984 Watt
Air pressure/ consumption	Max 6 bar/ 127.5L/min
Rpm	6000 min
Bevel width	0-15 mm
Bevel angle	Optional 30°, 37,5°, 45°, 50° or 60°
Cutting head	Optional
Weight	7.5 kg



Full automatic bevellingmachine

B 2 Air

Beveling Machine



Designed for deburring and rounding edges of parts and products made of steel, stainless steel, aluminum and other materials. Suitable for machining holes from the internal diameter of 6.8 mm / 0.24 in.

Chamfering angle:	45°
Chamfering width (hypotenuse):	2 mm / 0.08 i
Rounding radius:	R 1,5 mm / 0.06
Speed	23,000 rpm.
Feed	manual
Air consumption	320 l/min
Dimensions:	112 x 60 x 48 mm
Weight:	400 g / 0.88 Lbs
Number of cutting tips	3 pcs



Full automatic bevellingmachine



WITH THE FE LUBRICANT PROGRAM YOU GET THE BEST PERFORMANCE

High-performance lubricants and cutting oils from Fe Powertools are available for all applications in the metalworking industry.

FCO cutting oils and FEHS hand sprays are suitable for special work conditions and for all kinds of materials. The FCO oil is specially produced for Fe Powertools. This chlorine-free cutting oil allows for much better performance. Your cutting and threading will be much faster and easier, creating a better end result. The lifespan of your cutting tool will increase enormously. Professional workers only use FCO lubricants and cutting oils.



LUBRICANTS AND CUTTING OILS



FE Lubricants and cutting oils

Fe Powertools lubricants give you better results and extend the lifespan of your tools. High performance is guaranteed if you use the right FCO lubricants. Oil is not only necessary as a coolant, but it is also important for optimizing the cutting capacity of your tools. Therefore we offer the best additives to ensure your tools will cool down and cut more easily. For cutting tough materials, we also offer cutting paste FECP1. Moreover, if you have to cut above your head, we advise using cutting paste because it sticks to the tool and will not drip down. Another advantage of the cutting paste is that no grease is left after cutting, making the material easy to clean.



Cutting Oil and Cutting Paste

Art. No.	Type	Quantity
FCO 1.1	Cutting Oil	1 L
FCO 1.5	Cutting Oil	5 L
FCO 2.1	Cutting oil water dillutable	1 L
FCO 2.5	Cutting oil water dillutable	5 L
FCO 1.60	Cutting Oil	60 L
FCO 1.210	Cutting Oil	210 L
FCO 3.5	Cutting Oil	5 L Mist
FE CP 1	Cutting Paste	1000 grs
FEHS 001	Hand spray	400 ml (12 pcs)







Fe Powertools does its utmost to ensure that all technical information and recommendations are based upon good research and our wealth of experience. We provide the data in this catalogue in good faith, and, as such, accept no liability. We urge users to determine the suitability of the products shown for their particular intended use, and to ensure that they meet the relevant guidelines and codes for their country of intended use, as these may differ greatly from country to country. Please feel free to contact our technical staff, who would be delighted to advise you on specific regulatory issues. Fe Powertools reserves the rights to alter, delete or make obsolete any product featured in this catalogue without prior notice.

FEpowerTools®

**Fe Powertools® is a registered trademark.
We do not accept any misuse of our brand or logo.**

CE Declaration of Conformity

The following Fe Powertools machines conforms to the relevant guidelines:

Magnetic drilling machines:

FE 30X, FE 32X, FE 36S, FE 36X, FE 37 AUT, FE 50X, FE 50 RL X, FE 60X, FE 100 RL X

Beveling machines:

FEB 30, FEB 45, FEB R25, FEB 15/2 , FEB 20, FEB 25R, FEB 545 and FEB 645

Relevant guidelines:

- EC Directive 2006/42/EC on machinery
- EEC Directive 2014/30/EU concerning electro-magnetic compatibility

A conformity assessment method as provided in the directives has been executed.

The following harmonized standards were applied in whole or in part:

- DIN EN ISO 12100-2010
- DIN EN 61000-6-4:2007 + A1:2011
- DIN EN 55014-1:2006 + A1:2009 + A2:2011
- DIN EN 55014-2:1997 + Corr. 1997 + A1:2001 + A2:2008
- DIN EN 60745-1:2009
- DIN EN 60745-2-1:2010

Technical documentation is fully available. The operating instructions for the machine are available. It is required that the product is only operated as intended. Information on operating as intended can be obtained from the technical documentation.

Company:

Fe Powertools BV

Managing director;

Mark Korsten

Curieweg 30
Alphen aan den Rijn, February 2016
2408 BZ Alphen aan den Rijn
The Netherlands

www.kernboor.nl

www.fepowertools.nl

www.fepowertools.com

www.pijpzaagmachine.nl

FEpowerTools®

Fe Powertools bv
Curieweg 30
2408 BZ Alphen aan den Rijn
The Netherlands

T +31 (0)172 47 47 27
F +31 (0)172 47 29 49
E info@fepowertools.com

www.fepowertools.com